

*Allen-Bradley*

# **MicroLogix™ 1500 Programmable Controllers**

**Bulletin 1764**

**User Manual**

**Rockwell  
Automation**

## Important User Information

Because of the variety of uses for the products described in this publication, those responsible for the application and use of this control equipment must satisfy themselves that all necessary steps have been taken to assure that each application and use meets all performance and safety requirements, including any applicable laws, regulations, codes and standards.

The illustrations, charts, sample programs and layout examples shown in this guide are intended solely for purposes of example. Since there are many variables and requirements associated with any particular installation, Allen-Bradley does not assume responsibility or liability (to include intellectual property liability) for actual use based upon the examples shown in this publication.

Allen-Bradley publication SGI-1.1, *Safety Guidelines for the Application, Installation and Maintenance of Solid-State Control* (available from your local Allen-Bradley office), describes some important differences between solid-state equipment and electromechanical devices that should be taken into consideration when applying products such as those described in this publication.

Reproduction of the contents of this copyrighted publication, in whole or part, without written permission of Rockwell Automation, is prohibited.

Throughout this publication, notes may be used to make you aware of safety considerations. The following annotations and their accompanying statements help you to identify a potential hazard, avoid a potential hazard, and recognize the consequences of a potential hazard:

---

**WARNING**

Identifies information about practices or circumstances that can cause an explosion in a hazardous environment, which may lead to personal injury or death, property damage, or economic loss.

---

**ATTENTION**

Identifies information about practices or circumstances that can lead to personal injury or death, property damage, or economic loss.

---

**IMPORTANT**

Identifies information that is critical for successful application and understanding of the product.

---

## Summary of Changes

---

The information below summarizes the changes to this manual since the last printing.

To help you find new and updated information in this release of the manual, we have included change bars as shown to the right of this paragraph.

The table below lists the sections that document new features and additional or updated information on existing features.

<b>For this information:</b>	<b>See</b>
Series C support for up to 16 expansion I/O modules	Chapter 1
List of controller series, OS FRN numbers, and RSLogix versions	Page 1-5
Updated list of recommended surge suppressors	Page 3-6
Ethernet Connectivity	Page 4-23
Typical CPU hold-up time	Page A-1
Updated system loading and heat dissipation worksheets	Appendix F
System loading graphs for 1769 power supplies, including 1769-PA4 and 1769-PB4	pages F-5 through F-7



**Preface**

Who Should Use this Manual . . . . . P-1  
 Purpose of this Manual . . . . . P-1  
 Related Documentation . . . . . P-1  
 Common Techniques Used in this Manual . . . . . P-3  
 Rockwell Automation Support . . . . . P-3  
     Local Product Support . . . . . P-3  
     Technical Product Assistance . . . . . P-3  
     Your Questions or Comments on this Manual . . . . . P-4

**Chapter 1**

**Hardware Overview**

Hardware Features . . . . . 1-1  
 MicroLogix 1500 Component Descriptions . . . . . 1-2  
     Base Units . . . . . 1-2  
     Processors . . . . . 1-3  
     Data Access Tool (Catalog Number 1764-DAT) . . . . . 1-3  
     Memory Modules/Real-Time Clock . . . . . 1-4  
     Cables . . . . . 1-4  
 Programming . . . . . 1-5  
 Communication Options . . . . . 1-6  
 Compact™ Expansion I/O . . . . . 1-6  
     End Cap . . . . . 1-6  
     Expansion Power Supply and Cables . . . . . 1-7  
     System Requirements for Using Expansion Modules . . . . . 1-7  
     Adding an I/O Bank . . . . . 1-9  
     Addressing Expansion I/O . . . . . 1-11  
     Expansion I/O Power Failure . . . . . 1-11

**Chapter 2**

**Installing Your Controller**

Agency Certifications . . . . . 2-1  
 Compliance to European Union Directives . . . . . 2-1  
     EMC Directive . . . . . 2-1  
     Low Voltage Directive . . . . . 2-2  
 Installation Considerations . . . . . 2-2  
 Safety Considerations . . . . . 2-3  
     Hazardous Location Considerations . . . . . 2-3  
     Disconnecting Main Power . . . . . 2-4  
     Safety Circuits . . . . . 2-4  
     Power Distribution . . . . . 2-5  
     Periodic Tests of Master Control Relay Circuit . . . . . 2-5  
 Power Considerations . . . . . 2-5  
     Isolation Transformers . . . . . 2-5  
     Power Supply Inrush . . . . . 2-6  
     Loss of Power Source . . . . . 2-6

Input States on Power Down . . . . .	2-6
Other Types of Line Conditions . . . . .	2-7
Preventing Excessive Heat . . . . .	2-7
Master Control Relay . . . . .	2-8
Using Emergency-Stop Switches . . . . .	2-9
Schematic (Using IEC Symbols) . . . . .	2-10
Schematic (Using ANSI/CSA Symbols) . . . . .	2-11
Base Unit Mounting Dimensions . . . . .	2-12
Controller Spacing . . . . .	2-12
Mounting the Controller . . . . .	2-13
Using a DIN Rail . . . . .	2-14
Base Unit Panel Mounting . . . . .	2-16
Installing Controller Components . . . . .	2-17
Prevent Electrostatic Discharge . . . . .	2-17
Processor . . . . .	2-17
Data Access Tool (DAT) . . . . .	2-19
Memory Module/Real-Time Clock . . . . .	2-20
Compact I/O . . . . .	2-22

### Chapter 3

## Wiring Your Controller

Wiring Requirements . . . . .	3-1
Wiring Recommendation . . . . .	3-2
Using Surge Suppressors . . . . .	3-4
Recommended Surge Suppressors . . . . .	3-6
Grounding the Controller . . . . .	3-6
Wiring Diagrams . . . . .	3-8
Miswiring - 1764-28BXB Only . . . . .	3-8
Terminal Block Layouts . . . . .	3-9
Terminal Groupings . . . . .	3-10
Sinking and Sourcing Input Circuits . . . . .	3-10
1764-24AWA Wiring Diagram . . . . .	3-11
1764-24BWA Wiring Diagram with Sinking Inputs . . . . .	3-12
1764-24BWA Wiring Diagram with Sourcing Inputs . . . . .	3-13
1764-28BXB Wiring Diagram with Sinking Inputs . . . . .	3-14
1764-28BXB Wiring Diagram with Sourcing Outputs . . . . .	3-15
Controller I/O Wiring . . . . .	3-16
Minimizing Electrical Noise . . . . .	3-16
Transistor Output Transient Pulses . . . . .	3-16

### Chapter 4

## Communication Connections

Default Communication Configuration . . . . .	4-1
Communications Toggle Push Button . . . . .	4-2
Connecting to the RS-232 Port . . . . .	4-3
DF1 Full-Duplex Communication Parameters . . . . .	4-3
Making a DF1 Full-Duplex Point-to-Point Connection . . . . .	4-3

Using a Modem . . . . .	4-5
Isolated Modem Connection. . . . .	4-5
Connecting to a DF1 Half-Duplex Network. . . . .	4-7
Connecting to a DH-485 Network . . . . .	4-10
DH-485 Configuration Parameters. . . . .	4-12
Recommended Tools . . . . .	4-12
DH-485 Communication Cable . . . . .	4-12
Communication Cable Connection to the DH-485 Connector. . . . .	4-13
Connecting the AIC+ . . . . .	4-15
Connecting to DeviceNet . . . . .	4-22
Cable Selection Guide . . . . .	4-22
Connecting to Ethernet . . . . .	4-23
Ethernet Connections. . . . .	4-23
RS-232 Connections . . . . .	4-24

## Chapter 5

### Using Trim Pots and the Data Access Tool (DAT)

Trim Pot Operation . . . . .	5-1
Trim Pot Information Function File . . . . .	5-2
Error Conditions . . . . .	5-2
Data Access Tool (DAT) . . . . .	5-2
DAT Keypad and Indicator Light Functions. . . . .	5-2
Power-Up Operation . . . . .	5-3
DAT Function File . . . . .	5-4
Power Save Timeout (PST) Parameter. . . . .	5-4
Understanding the DAT Display . . . . .	5-5
Entering Bit Mode . . . . .	5-6
Entering Integer Mode . . . . .	5-6
Monitoring and Editing. . . . .	5-6
F1 and F2 Functions. . . . .	5-7
Working Screen Operation. . . . .	5-7
Non-Existent Elements . . . . .	5-8
Controller Faults . . . . .	5-8
Error Conditions . . . . .	5-9

## Chapter 6

### Using Real-Time Clock and Memory Modules

Real-Time Clock Operation . . . . .	6-1
Removal/Insertion Under Power. . . . .	6-1
Real-Time Clock Function File . . . . .	6-1
Accuracy . . . . .	6-2
Writing Data to the Real-Time Clock. . . . .	6-2
RTC Battery Operation. . . . .	6-2
Memory Module Operation . . . . .	6-3
User Program and Data Back-Up . . . . .	6-3
Program Compare . . . . .	6-4

Data File Download Protection . . . . . 6-4  
 Memory Module Write Protection . . . . . 6-5  
 Removal/Insertion Under Power . . . . . 6-5  
 Memory Module Information File . . . . . 6-5

**Specifications**

**Appendix A**

Controller Specifications . . . . . A-1  
     Choosing a Power Supply . . . . . A-2  
     Transistor Output Transient Pulses . . . . . A-8  
 Controller Dimensions . . . . . A-9  
 Compact I/O Dimensions . . . . . A-9  
     Panel Mounting . . . . . A-9  
     End Cap . . . . . A-10

**Replacement Parts**

**Appendix B**

MicroLogix 1500 Replacement Kits . . . . . B-1  
 Lithium Battery (1747-BA) . . . . . B-2  
     Installing . . . . . B-2  
     Battery Handling . . . . . B-3  
     Storing . . . . . B-3  
     Transporting . . . . . B-3  
     Disposing . . . . . B-4  
 Replacement Terminal Blocks . . . . . B-5  
 Replacement Doors . . . . . B-6  
     Base Terminal Door (1764-RPL-TDR1) . . . . . B-6  
     Processor Access Door (1764-RPL-CDR1) . . . . . B-6  
     Base Comms Door  
     (included in 1764-RPL-DR) . . . . . B-6  
     Trim Pots/Mode Switch Cover Door  
     (included in 1764-RPL-DR) . . . . . B-6

**Troubleshooting Your System**

**Appendix C**

Understanding Controller LEDs . . . . . C-1  
     When Operating Normally . . . . . C-2  
     When an Error Exists . . . . . C-2  
 Controller Error Recovery Model . . . . . C-3  
 Identifying Controller Faults . . . . . C-4  
     Automatically Clearing Faults . . . . . C-4  
     Manually Clearing Faults Using the Fault Routine . . . . . C-4  
     Fault Messages . . . . . C-5  
 Calling Rockwell Automation for Assistance . . . . . C-5



	<b>Appendix D</b>	
<b>Upgrading Your Operating System</b>	Preparing for Upgrade . . . . .	D-1
	Performing the Upgrade . . . . .	D-2
	Missing/Corrupt OS LED Pattern . . . . .	D-2
	<b>Appendix E</b>	
<b>Understanding Communication Protocols</b>	RS-232 Communication Interface . . . . .	E-1
	DF1 Full-Duplex Protocol . . . . .	E-1
	DF1 Half-Duplex Protocol . . . . .	E-2
	DF1 Half-Duplex Operation . . . . .	E-2
	Considerations When Communicating as a DF1 Slave on a Multi-drop Link . . . . .	E-3
	Using Modems with MicroLogix 1500	
	Programmable Controllers . . . . .	E-3
	Dial-Up Phone Modems . . . . .	E-4
	Leased-Line Modems . . . . .	E-4
	Radio Modems . . . . .	E-5
	Line Drivers . . . . .	E-5
	DH-485 Communication Protocol . . . . .	E-5
	DH-485 Network Description . . . . .	E-5
	DH-485 Token Rotation . . . . .	E-6
	DH-485 Configuration Parameters . . . . .	E-6
	Devices that Use the DH-485 Network . . . . .	E-7
	Important DH-485 Network Planning Considerations . . . . .	E-8
	Modbus RTU Slave Communication Protocol (MicroLogix 1764-LSP and 1764-LRP Series B and later processors only) . . . . .	E-13
	ASCII Protocol (MicroLogix 1500 1764-LSP and 1764-LRP Series B and later Processors only) . . . . .	E-13
	<b>Appendix F</b>	
<b>System Loading and Heat Dissipation</b>	System Loading Limitations . . . . .	F-1
	System Expansion Calculations . . . . .	F-1
	Selecting System Devices . . . . .	F-2
	Verifying the System Loading . . . . .	F-4
	Calculating Heat Dissipation . . . . .	F-9

## Glossary

## Index



Read this preface to familiarize yourself with the rest of the manual. It provides information concerning:

- who should use this manual
- the purpose of this manual
- related documentation
- conventions used in this manual
- Rockwell Automation support

### Who Should Use this Manual

Use this manual if you are responsible for designing, installing, programming, or troubleshooting control systems that use MicroLogix 1500 controllers.

You should have a basic understanding of electrical circuitry and familiarity with relay logic. If you do not, obtain the proper training before using this product.

### Purpose of this Manual

This manual is a reference guide for MicroLogix 1500 controllers. It describes the procedures you use to install, wire, and troubleshoot your controller. This manual:

- explains how to install and wire your controllers
- gives you an overview of the MicroLogix 1500 controller system

Refer to publication 1762-RM001, *MicroLogix 1200 and MicroLogix 1500 Programmable Controllers Instruction Set Reference Manual* for the MicroLogix 1200 and 1500 instruction set and for application examples to show the instruction set in use. Refer to your programming software user documentation for more information on programming your MicroLogix 1500 controller.

### Related Documentation

The documents listed on page P-2 contain additional information concerning Rockwell Automation products. If you would like a copy, you can:

- download a free electronic version from the internet:  
[www.ab.com/micrologix](http://www.ab.com/micrologix) or [www.theautomationbookstore.com](http://www.theautomationbookstore.com)
- purchase a printed manual by:
  - contacting your local distributor or Rockwell Automation representative
  - visiting [www.theautomationbookstore.com](http://www.theautomationbookstore.com) and placing your order
  - calling 1.800.963.9548 (USA/Canada)  
or 001.330.725.1574 (Outside USA/Canada)

<b>For</b>	<b>Read this Document</b>	<b>Document Number</b>
A technical overview of the MicroLogix 1500 and related products	MicroLogix 1500 Programmable Controllers Technical Data	1764-TD001
Information on the MicroLogix 1500 Controllers instruction set	MicroLogix 1200 and 1500 Programmable Controllers Instruction Set Reference Manual	1762-RM001
Information on mounting and wiring the MicroLogix 1500 Base Units, including a mounting template for easy installation	MicroLogix 1500 Programmable Controllers Base Unit Installation Instructions	1764-IN001
An overview of Compact I/O	Compact I/O System Overview	1769-SO001
More information on Compact I/O Power Supplies and Cables	1769 Compact I/O Power Supplies and Communication Bus Expansion Cables Technical Data	1769-TD001
More information on Compact Analog I/O and Temperature Input Modules	Compact Analog I/O and Temperature Input Modules Technical Data	1769-TD004
Detailed information on using Compact I/O Analog Modules	Compact I/O Analog Modules User Manual	1769-UM002
Detailed information on installing, configuring, and using 1769-IT6 Thermocouple/mV Input Modules	Compact I/O 1769-IT6 Thermocouple/mV Input Module User Manual	1769-UM004
Detailed information on installing, configuring, and using 1769-IR6 RTD/Resistance Input Modules	Compact I/O 1769-IR6 RTD/Resistance Input Module User Manual	1769-UM005
Detailed information on installing, configuring, and using 1769-HSC High Speed Counter Modules	Compact 1769-HSC High Speed Counter Module User Manual	1769-UM006
A description on how to install and connect an AIC+. This manual also contains information on network wiring.	Advanced Interface Converter (AIC+) User Manual	1761-6.4
Information on how to install, configure, and commission a DNI	DeviceNet™ Interface User Manual	1761-6.5
Information on installing, connecting, and configuring an ENI	Ethernet Interface User Manual	1761-UM001
Information on installing, configuring, and using a DeviceNet Scanner	Compact™ I/O 1769-SDN DeviceNet Scanner User Manual	1761-UM009
Information on DF1 open protocol.	DF1 Protocol and Command Set Reference Manual	1770-6.5.16
In-depth information on grounding and wiring Allen-Bradley programmable controllers	Allen-Bradley Programmable Controller Grounding and Wiring Guidelines	1770-4.1
A description of important differences between solid-state programmable controller products and hard-wired electromechanical devices	Application Considerations for Solid-State Controls	SGI-1.1
An article on wire sizes and types for grounding electrical equipment	National Electrical Code - Published by the National Fire Protection Association of Boston, MA.	
A complete listing of current documentation, including ordering instructions. Also indicates whether the documents are available on CD-ROM or in multi-languages.	Allen-Bradley Publication Index	SD499
A glossary of industrial automation terms and abbreviations	Allen-Bradley Industrial Automation Glossary	AG-7.1

## **Common Techniques Used in this Manual**

The following conventions are used throughout this manual:

- Bulleted lists such as this one provide information, not procedural steps.
- Numbered lists provide sequential steps or hierarchical information.
- *Italic* type is used for emphasis.

## **Rockwell Automation Support**

Rockwell Automation offers support services worldwide, with over 75 Sales/Support Offices, 512 authorized Distributors and 260 authorized Systems Integrators located throughout the United States alone, plus Rockwell Automation representatives in every major country in the world.

### **Local Product Support**

Contact your local Rockwell Automation representative for:

- sales and order support
- product technical training
- warranty support
- support service agreements

### **Technical Product Assistance**

Before you contact Rockwell Automation for technical assistance, we suggest you please review the troubleshooting information contained in this publication first.

If the problem persists, call your local Rockwell Automation representative or contact Rockwell Automation in one of the following ways:

<b>Phone</b>	United States/Canada	1.440.646.5800
	Outside United States/Canada	You can access the phone number for your country via the Internet: <ol style="list-style-type: none"> <li>1. Go to <a href="http://www.ab.com">http://www.ab.com</a></li> <li>2. Click on <i>Product Support</i> (<a href="http://support.automation.rockwell.com">http://support.automation.rockwell.com</a>)</li> <li>3. Under <i>Support Centers</i>, click on <i>Contact Information</i></li> </ol>
<b>Internet</b>	⇒	<ol style="list-style-type: none"> <li>1. Go to <a href="http://www.ab.com">http://www.ab.com</a></li> <li>2. Click on <i>Product Support</i> (<a href="http://support.automation.rockwell.com">http://support.automation.rockwell.com</a>)</li> </ol>

## Your Questions or Comments on this Manual

If you find a problem with this manual, or you have any suggestions for how this manual could be made more useful to you, please contact us at the address below:

Rockwell Automation  
Automation Control and Information Group  
Technical Communication, Dept. A602V  
P.O. Box 2086  
Milwaukee, WI 53201-2086

or visit our internet page at:

<http://www.rockwellautomation.com>

For the latest information on MicroLogix controllers, visit [www.ab.com/micrologix](http://www.ab.com/micrologix)

## Hardware Overview

### Hardware Features

The MicroLogix 1500 programmable controller is composed of a base unit, which contains a power supply, input and output circuits, and a processor. The controller is available with 24 or 28 points of embedded I/O. Additional I/O may be added using Compact™ I/O.

The hardware features of the controller are:

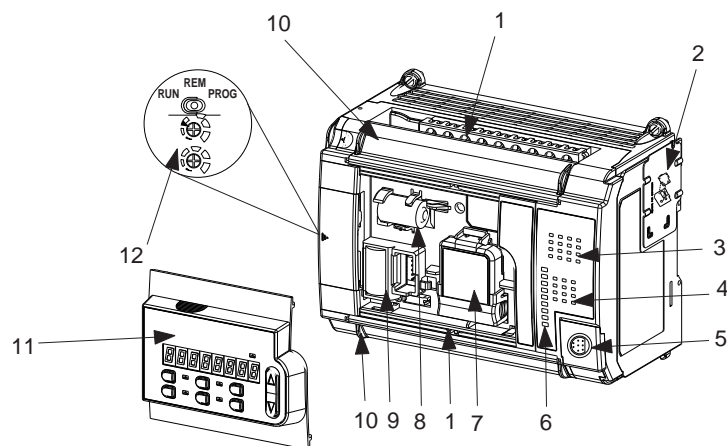

Feature	Description	Feature	Description
1	Removable Terminal Blocks	7	Memory Module/Real-Time Clock <sup>(1)</sup>
2	Interface to Expansion I/O, Removable ESD Barrier	8	Replacement Battery <sup>(1)</sup>
3	Input LEDs	9	Battery
4	Output LEDs	10	Terminal Doors and Label
5	Communication Port	11	Data Access Tool <sup>(1)</sup>
6	Status LEDs	12	Mode Switch, Trim Pots

(1) Optional.

## ■ MicroLogix 1500 Component Descriptions

A controller is composed of a processor (1764-LSP or enhanced 1764-LRP with RS-232 port) and one of the base units listed below. The FET transistor outputs are available on the 1764-28BXB base only.

### Base Units

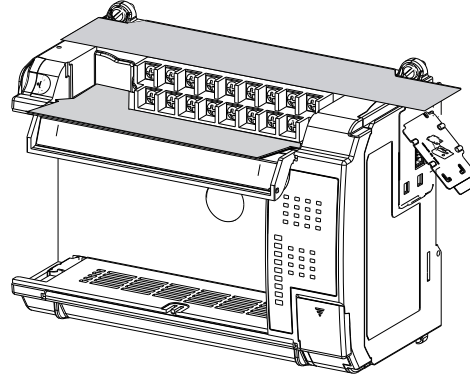

Catalog Number	Line Power	Inputs	Outputs	High Speed I/O
1764-24AWA	120/240V ac	(12) 120V ac	(12) Relay, 2 isolated relays per unit	n/a
1764-24BWA	120/240V ac	(8) Standard 24V dc (4) Fast 24V dc	(12) Relay, 2 isolated relays per unit	(4) 20 kHz input
1764-28BXB	24V dc	(8) Standard 24V dc (8) Fast 24V dc	(6) Relay, 2 isolated relays per unit (4) Standard 24V dc FET (2) Fast 24V dc FET	(8) 20 kHz input (2) 20 kHz output



## Processors

*Processor (Catalog Number 1764-LSP)*

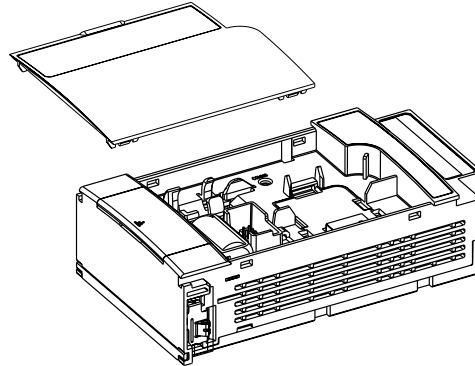

*Processor (Catalog Number 1764-LRP)*

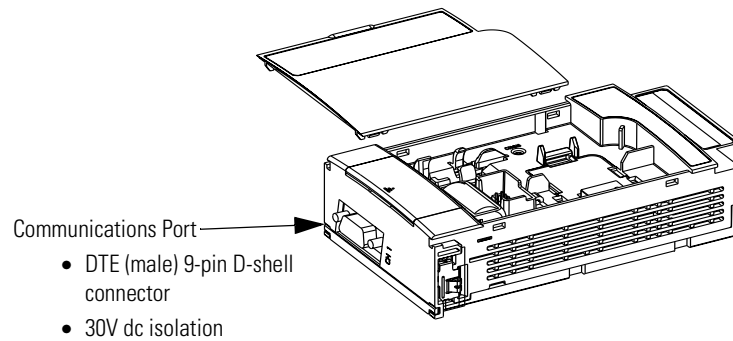

## Data Access Tool (Catalog Number 1764-DAT)

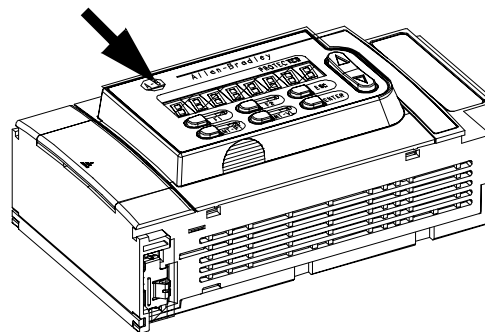

1764-DAT  
mounted on  
1764-LSP  
processor.

## Memory Modules/Real-Time Clock

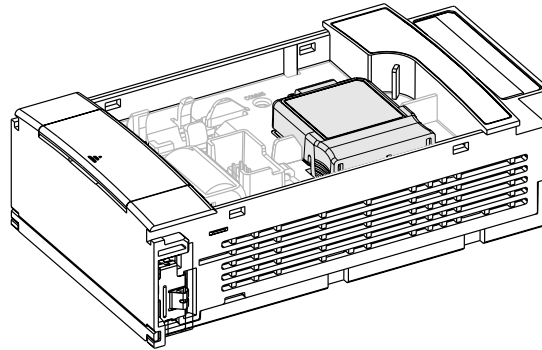

Memory module mounted on 1764-LSP processor.

The following memory modules and real-time clock modules are available:

Catalog Number	Function	Memory Size
1764-RTC	Real-Time Clock	not applicable
1764-MM1	Memory Module	8K
1764-MM1RTC	Memory Module and Real-Time Clock	8K
1764-MM2 <sup>(1)</sup>	Memory Module	16K
1764-MM2RTC <sup>(1)</sup>	Memory Module and Real-Time Clock	16K

(1) For 1764-LRP programs greater than 8k, use the 1764-MM2 or 1764-MM2RTC.

## Cables

Use only the following communication cables in Class I, Division 2 hazardous locations.

**Table 1.1 Cables for Use in Class I, Division 2 Hazardous Environment**

1761-CBL-PM02 Series C or later	2707-NC8 Series B or later
1761-CBL-HM02 Series C or later	2707-NC9 Series B or later
1761-CBL-AM00 Series C or later	2707-NC10 Series B or later
1761-CBL-AP00 Series C or later	2707-NC11 Series B or later

## Programming

Programming the MicroLogix 1500 programmable controller is done using RSLogix™ 500, Rev. 4.0 or later. Certain features are only available when using the most current version of the software, as noted in System Requirements for Using Expansion Modules on page 1-7.

The following table lists the firmware release numbers, feature and functionality enhancements, and the required version of RSLogix 500 and RSLogix 500 Starter software.

**Table 1.B Required Software Version by FRN Number**

Controller	Firmware Release	Available for Sale Date	Catalog Number Series	Catalog Number Revision	OS FRN Number	Feature and Functionality Changes	Required Version of RSLogix 500/RSLogix 500 Starter Software
1764-LSP	Initial Release	February 1999	A	B	2	Initial Release	3.01.00
	Enhancement	October 1999	A	C	3	Power Supply and Expansion Cable Compatibility	3.01.00
	Series B Release	March 2000	B	A	4	String Data File Type, ASCII Instruction Set, Modbus RTU Slave Protocol, Ramping (when using PWM outputs), Static Data File Protection, RTC Messaging	4.00.00
	Enhancement	October 2000	B	B	5	PTO Controlled Stop, Memory Module Program Compare Bit Enhancement	4.50.00
	Series C Release	September 2001	C	A	6	Floating Point Data File Support, Programmable Limit Switch (PLS), Real Time Clock Adjust (Copy Word), Absolute Value, Gray Code, Recipe, Message Instruction Support for 1769-SDN	5.10.00
1764-LRP	Initial Release	March 2000	B	A	4	Initial Release - Same Functionality as 1764-LSP	4.00.00
	Enhancement	October 2000	B	B	5	PTO Controlled Stop, Memory Module Program Compare Bit Enhancement	4.50.00
	Series C Release	September 2001	C	A	6	Floating Point Data File Support, Programmable Limit Switch (PLS), Real Time Clock Adjust (Copy Word), Absolute Value, Gray Code, Recipe, Message Instruction Support for 1769-SDN	5.10.00

## Communication Options

The MicroLogix 1500 can be connected to a personal computer. It can also be connected to the DH-485 network using an Advanced Interface Converter (1761-NET-AIC), to an Ethernet network using an Ethernet Interface (1761-NET-ENI), or to a DeviceNet™ network using a DeviceNet Interface (1761-NET-DNI) or through the DeviceNet Scanner module (1769-SDN). The controller can also be connected to Modbus™ SCADA networks as an RTU slave. See Communication Connections on page 4-1 for more information on connecting to the available communication options.

The 1764-LRP processor provides an additional communication port. Each of the communications ports can be independently configured for any supported communication protocol. (Channel 0 is on the base unit and Channel 1 is on the 1764-LRP processor.)

## Compact™ Expansion I/O

Compact expansion I/O (Bulletin 1769) can be connected to the MicroLogix 1500 Controller. A maximum of either 8 or 16 expansion I/O modules can be used, depending upon your system. See System Requirements for Using Expansion Modules on page 1-7.

See System Loading and Heat Dissipation on page F-1 for more information on system configurations.

## End Cap

An end cap terminator (catalog number 1769-ECR or 1769-ECL) must be used at the end of the group of I/O modules attached to the MicroLogix 1500 Controller. The end cap terminator is not provided with the base or processor units. It is required when using expansion I/O.

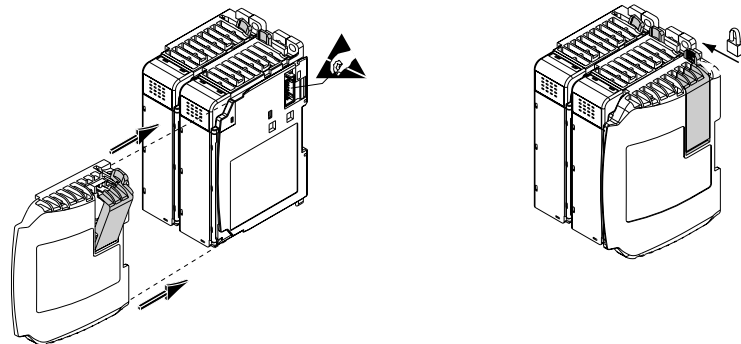

This illustration shows the right end cap (1769-ECR). The left end cap (1769-ECL) is shown on page 1-10.

## Expansion Power Supply and Cables

With Operating System Revision Number (FRN) 3 or higher, you can connect an additional bank of I/O to your controller. Using an expansion power supply increases the system's capacity for adding expansion I/O modules. The additional I/O bank is connected to the controller via a specially designed cable. The additional I/O bank must include a power supply and an end cap.

### TIP



Depending on the system configuration, each controller can support up to 16 expansion I/O modules. See the System Requirements for Using Expansion Modules below. Also see System Guidelines on page 1-9 for system limitations and illustrations of expansion I/O banks.

## System Requirements for Using Expansion Modules

To support a maximum of 8 I/O modules in an additional I/O bank, you must have the following:

**Table 1.3 Requirements to Support a Maximum of 8 I/O Modules**

Product	Catalog Number	
MicroLogix 1500 Processor	1764-LSP, Series A, Revision C or higher 1764-LSP, Series B or higher 1764-LRP, Series B or higher	
MicroLogix 1500 Base Unit	1764-24AWA, Series A or higher 1764-24BWA, Series A or higher 1764-28BXB, Series A or higher	
Operating System Version	Firmware Revision Number (FRN) 3 or higher <sup>(1)</sup>	
Programming Software	1764-LSP, Series A	RSLogix 500, Version 3.01.09 or higher,
	1764-LSP, Series B 1764-LRP, Series B	RSLogix 500, Version 4.00.00 or higher.
	1764-LSP, Series C 1764-LRP, Series C	RSLogix 500, Version 5.00.00 or higher.
1 Power Supply (optional)	1769-PA2, 1769-PA4 1769-PB2, 1769-PB4	
1 Cable (optional)	1769-CRL1, 1769-CRL3, 1769-CRR1, 1769-CRR3	
1 End Cap (required)	1769-ECL, 1769-ECR	

(1) You can check the FRN by looking at word S:59 (Operating System FRN) in the Status File.

To support a maximum of 16 I/O modules in an additional I/O bank, you must have the following:

**Table 1.4 Requirements to Support a Maximum of 16 I/O Modules**

Product	Catalog Number
MicroLogix 1500 Processor	1764-LSP, Series C or higher 1764-LRP, Series C or higher
MicroLogix 1500 Base Unit	1764-24AWA, Series B or higher 1764-24BWA, Series B or higher 1764-28BXB, Series B or higher
Operating System Version	Firmware Revision Number (FRN) 6 or higher <sup>(1)</sup>
Programming Software	RSLogix 500, Version 5.10.00 or higher.
1 Power Supply (optional)	1769-PA2, 1769-PA4, 1769-PB2, 1769-PB4
1 Cable (optional)	1769-CRL1, 1769-CRL3, 1769-CRR1, 1769-CRR3
1 End Cap (required)	1769-ECL, 1769-ECR

(1) You can check the FRN by looking at word S:59 (Operating System FRN) in the Status File.

### IMPORTANT

If your processor is at an older revision, you *must* upgrade the operating system to FRN 3 or higher to use an expansion cable and power supply (or to FRN 6 or higher to allow up to 16 expansion modules). On the Internet, go to <http://www.ab.com/micrologix> to download the operating system upgrade. Navigate to MicroLogix 1500 for further instructions and downloads.

MicroLogix 1500 base units are *not* field upgradeable from Series A to Series B.

---

## Adding an I/O Bank

### *System Guidelines*

A maximum of one 1769 Expansion Cable can be used in a MicroLogix 1500 system, allowing for two banks of I/O modules (one connected directly to the controller, and the other connected via the cable). Each I/O bank requires its own power supply (Bank 1 uses the controller's embedded power supply).

---

**ATTENTION****LIMIT OF ONE EXPANSION POWER SUPPLY**

The expansion power supply cannot be connected directly to the controller. It must be connected using an expansion cable. Only one power supply (embedded in the base unit or an expansion power supply) may be used on an I/O bank. Exceeding these limitations may damage the power supply and result in unexpected operation.

---

**ATTENTION****REMOVE POWER**

Remove system power before making or breaking cable connections. When you remove or insert a cable connector with power applied, an electrical arc may occur. An electrical arc can cause personal injury or property damage by:

- sending an erroneous signal to your system's field devices, causing unintended machine operation
- causing an explosion in a hazardous environment

Electrical arcing causes excessive wear to contacts on both the module and its mating connector.

Refer to your power supply and I/O module's documentation for instructions on how to set up your system.

---

**IMPORTANT**

See the System Requirements for Using Expansion Modules on page 1-7 to determine the maximum number of expansion I/O modules you can use in your MicroLogix system.

Also see System Loading and Heat Dissipation on page F-1 for more information on system configurations.

---

The following illustrations show a MicroLogix 1500 with an expansion I/O bank.

*Vertical Orientation*

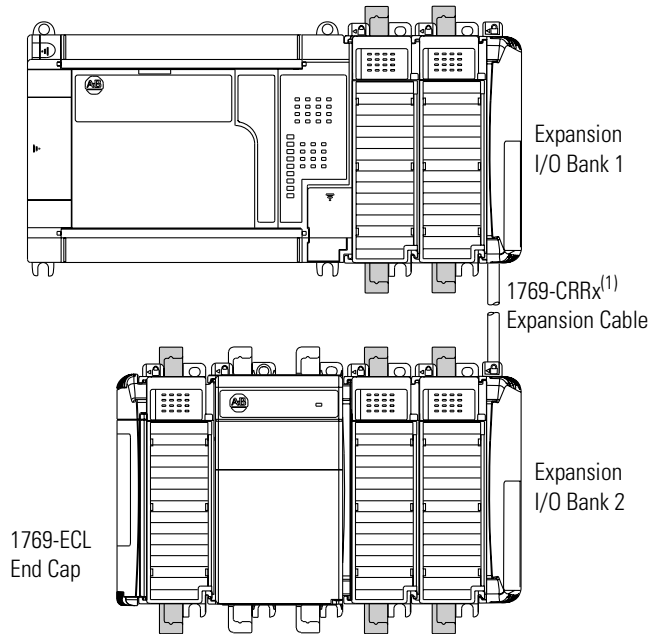

(1) The x in this catalog number can be either a 1 or a 3 representing the length of the cable: 1 = 1 foot (305 mm) and 3 = 3.28 feet (1 meter).

*Horizontal Orientation*

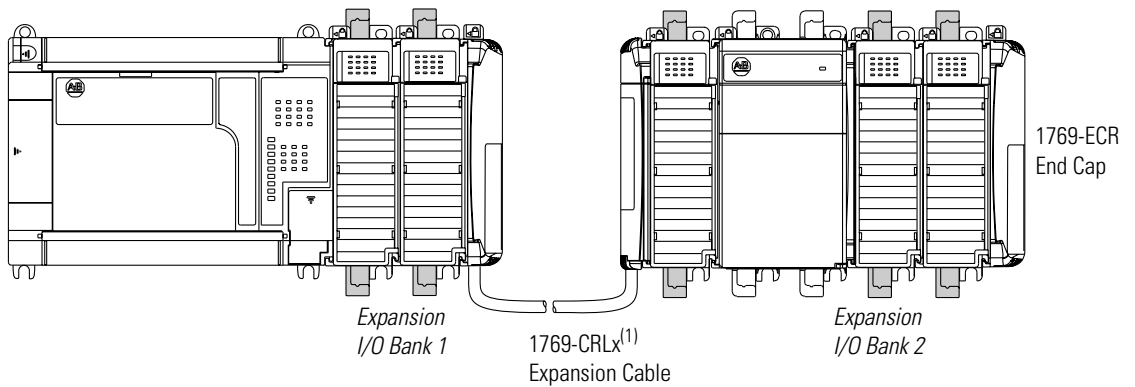

(1) The x in this catalog number can be either a 1 or a 3 representing the length of the cable: 1 = 1 foot (305 mm) and 3 = 3.28 feet (1 meter).



## Addressing Expansion I/O

The expansion I/O is addressed as slots 1 through 16 (the controller's embedded I/O is addressed as slot 0). Power supplies and cables are not counted as slots. Modules are counted from left to right on each bank as shown in the illustrations below. For more information on addressing, refer to the *MicroLogix 1200 and MicroLogix 1500 Programmable Controllers Instruction Set Reference Manual*, publication 1762-RM001.

### Vertical Orientation

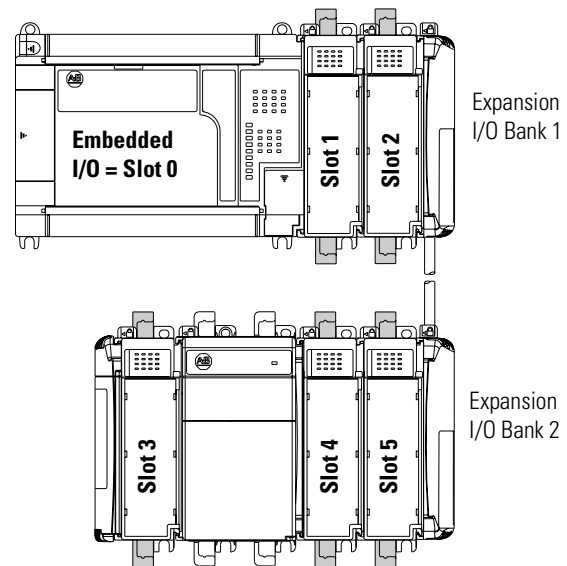

### Horizontal Orientation

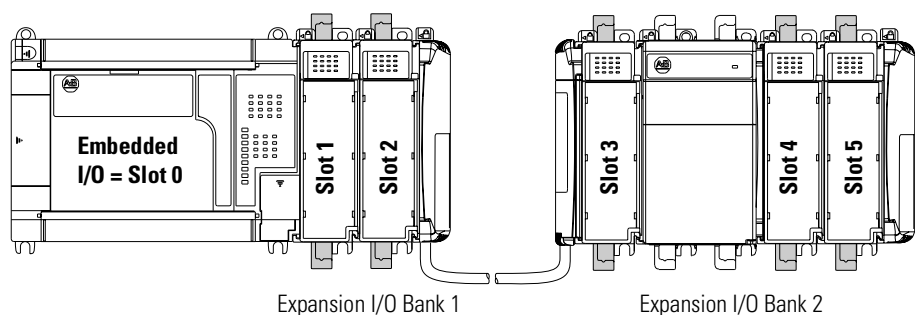

## Expansion I/O Power Failure

Expansion I/O errors represent failures of the I/O bus or the modules themselves. The error codes are listed in the *MicroLogix 1200 and MicroLogix 1500 Programmable Controllers Instruction Set Reference Manual*, publication 1762-RM001.



## Installing Your Controller

This chapter shows you how to install your controller system. The only tools you require are a Flat or Phillips head screwdriver and drill. Topics include:

- agency certifications
- compliance to European Union Directives
- using in hazardous locations
- master control relay
- power considerations
- preventing excessive heat
- controller spacing
- mounting the controller

### Agency Certifications

- UL 508
- C-UL under CSA C22.2 no. 142
- Class I, Division 2, Groups A, B, C, D (UL 1604, C-UL under CSA C22.2 no. 213)
- CE compliant for all applicable directives

### Compliance to European Union Directives

This product has the CE mark and is approved for installation within the European Union and EEA regions. It has been designed and tested to meet the following directives.

#### EMC Directive

This product is tested to meet Council Directive 89/336/EEC Electromagnetic Compatibility (EMC) and the following standards, in whole or in part, documented in a technical construction file:

- EN 50081-2  
EMC - Generic Emission Standard, Part 2 - Industrial Environment
- EN 50082-2  
EMC - Generic Immunity Standard, Part 2 - Industrial Environment

This product is intended for use in an industrial environment.

## Low Voltage Directive

This product is tested to meet Council Directive 73/23/EEC Low Voltage, by applying the safety requirements of EN 61131-2 Programmable Controllers, Part 2 - Equipment Requirements and Tests.

For specific information required by EN 61131-2, see the appropriate sections in this publication, as well as the following Allen-Bradley publications:

- *Industrial Automation Wiring and Grounding Guidelines for Noise Immunity*, publication 1770-4.1
- *Guidelines for Handling Lithium Batteries*, publication AG-5.4
- *Automation Systems Catalog*, publication B111

## Installation Considerations

Most applications require installation in an industrial enclosure (Pollution Degree 2<sup>(1)</sup>) to reduce the effects of electrical interference (Over Voltage Category II<sup>(2)</sup>) and environmental exposure. Locate your controller as far as possible from power lines, load lines, and other sources of electrical noise such as hard-contact switches, relays, and AC motor drives. For more information on proper grounding guidelines, see the *Industrial Automation Wiring and Grounding Guidelines* publication 1770-4.1.

---

**ATTENTION**

Vertical mounting of the controller is not recommended due to heat build-up considerations.

---

---

**ATTENTION**

Be careful of metal chips when drilling mounting holes for your controller or other equipment within the enclosure or panel. Drilled fragments that fall into the base or processor unit could cause damage. Do not drill holes above a mounted controller if the protective debris strips are removed or the processor is installed.

---

(1) Pollution Degree 2 is an environment where normally only non-conductive pollution occurs except that occasionally temporary conductivity caused by condensation shall be expected.

(2) Overvoltage Category II is the load level section of the electrical distribution system. At this level transient voltages are controlled and do not exceed the impulse voltage capability of the products insulation.

## Safety Considerations

Safety considerations are an important element of proper system installation. Actively thinking about the safety of yourself and others, as well as the condition of your equipment, is of primary importance. We recommend reviewing the following safety considerations.

### Hazardous Location Considerations

This equipment is suitable for use in Class I, Division 2, Groups A, B, C, D or non-hazardous locations only. The following WARNING statement applies to use in hazardous locations.

---

**WARNING****EXPLOSION HAZARD**

- Substitution of components may impair suitability for Class I, Division 2.
- Do not replace components or disconnect equipment unless power has been switched off.
- Do not connect or disconnect components unless power has been switched off, or the area is known to be non-hazardous.
- This product must be installed in an enclosure. All cables connected to the product must remain in the enclosure or be protected by conduit or other means.
- All wiring must comply with N.E.C. article 501-4(b).

---

**WARNING**

When installing any peripheral device (for example, push buttons, lamps) into a hazardous environment, ensure that they are Class I, Division 2 certified, or determined to be safe for the environment.

---

Use only the following communication cables in Class I, Division 2 hazardous locations.

**Table 2.1 Cables for Use in Class I, Division 2 Hazardous Environment**

1761-CBL-PM02 Series C or later	2707-NC8 Series B or later
1761-CBL-HM02 Series C or later	2707-NC9 Series B or later
1761-CBL-AM00 Series C or later	2707-NC10 Series B or later
1761-CBL-AP00 Series C or later	2707-NC11 Series B or later

## Disconnecting Main Power

### WARNING



#### EXPLOSION HAZARD

Do not replace components or disconnect equipment unless power has been switched off.

The main power disconnect switch should be located where operators and maintenance personnel have quick and easy access to it. In addition to disconnecting electrical power, all other sources of power (pneumatic and hydraulic) should be de-energized before working on a machine or process controlled by a controller.

## Safety Circuits

### WARNING



#### EXPLOSION HAZARD

Do not connect or disconnect connectors while circuit is live.

Circuits installed on the machine for safety reasons, like overtravel limit switches, stop push buttons, and interlocks, should always be hard-wired directly to the master control relay. These devices must be wired in series so that when any one device opens, the master control relay is de-energized, thereby removing power to the machine. Never alter these circuits to defeat their function. Serious injury or machine damage could result.

## Power Distribution

There are some points about power distribution that you should know:

- The master control relay must be able to inhibit all machine motion by removing power to the machine I/O devices when the relay is de-energized. It is recommended that the controller remain powered even when the master control relay is de-energized.
- If you are using a dc power supply, interrupt the load side rather than the ac line power. This avoids the additional delay of power supply turn-off. The dc power supply should be powered directly from the fused secondary of the transformer. Power to the dc input and output circuits should be connected through a set of master control relay contacts.

## Periodic Tests of Master Control Relay Circuit

Any part can fail, including the switches in a master control relay circuit. The failure of one of these switches would most likely cause an open circuit, which would be a safe power-off failure. However, if one of these switches shorts out, it no longer provides any safety protection. These switches should be tested periodically to assure they will stop machine motion when needed.

## Power Considerations

The following explains power considerations for the micro controllers.

### Isolation Transformers

You may want to use an isolation transformer in the ac line to the controller. This type of transformer provides isolation from your power distribution system to reduce the electrical noise that enters the controller and is often used as a step-down transformer to reduce line voltage. Any transformer used with the controller must have a sufficient power rating for its load. The power rating is expressed in volt-amperes (VA).

## Power Supply Inrush

During power-up, the MicroLogix 1500 power supply allows a brief inrush current to charge internal capacitors. Many power lines and control transformers can supply inrush current for a brief time. If the power source cannot supply this inrush current, the source voltage may sag momentarily.

The only effect of limited inrush current and voltage sag on the MicroLogix 1500 is that the power supply capacitors charge more slowly. However, the effect of a voltage sag on other equipment should be considered. For example, a deep voltage sag may reset a computer connected to the same power source. The following considerations determine whether the power source must be required to supply high inrush current:

- The power-up sequence of devices in a system.
- The amount of the power source voltage sag if the inrush current cannot be supplied.
- The effect of voltage sag on other equipment in the system.

If the entire system is powered-up at the same time, a brief sag in the power source voltage typically will not affect any equipment.

## Loss of Power Source

The power supply is designed to withstand brief power losses without affecting the operation of the system. The time the system is operational during power loss is called “program scan hold-up time after loss of power.” The duration of the power supply hold-up time depends on the type and state of the I/O, but is typically between 10 milliseconds and 3 seconds. When the duration of power loss reaches this limit, the power supply signals the processor that it can no longer provide adequate dc power to the system. This is referred to as a power supply shutdown. The processor then performs an orderly shutdown of the controller.

## Input States on Power Down

The power supply hold-up time as described above is generally longer than the turn-on and turn-off times of the inputs. Because of this, the input state change from “On” to “Off” that occurs when power is removed may be recorded by the processor before the



power supply shuts down the system. Understanding this concept is important. Write the user program, taking this effect into account.

### Other Types of Line Conditions

Occasionally the power source to the system can be temporarily interrupted. It is also possible that the voltage level may drop substantially below the normal line voltage range for a period of time. Both of these conditions are considered to be a loss of power for the system.

### Preventing Excessive Heat

For most applications, normal convective cooling keeps the controller within the specified operating range. Ensure that the specified temperature range is maintained. Proper spacing of components within an enclosure is usually sufficient for heat dissipation.

In some applications, a substantial amount of heat is produced by other equipment inside or outside the enclosure. In this case, place blower fans inside the enclosure to assist in air circulation and to reduce “hot spots” near the controller.

Additional cooling provisions might be necessary when high ambient temperatures are encountered.

**TIP**

Do not bring in unfiltered outside air. Place the controller in an enclosure to protect it from a corrosive atmosphere. Harmful contaminants or dirt could cause improper operation or damage to components. In extreme cases, you may need to use air conditioning to protect against heat build-up within the enclosure.

## Master Control Relay

A hard-wired master control relay (MCR) provides a reliable means for emergency machine shutdown. Since the master control relay allows the placement of several emergency-stop switches in different locations, its installation is important from a safety standpoint. Overtravel limit switches or mushroom-head push buttons are wired in series so that when any of them opens, the master control relay is de-energized. This removes power to input and output device circuits. Refer to the figures on pages 2-10 and 2-11.

---

**ATTENTION**

Never alter these circuits to defeat their function since serious injury and/or machine damage could result.

---

**TIP**

If you are using an external dc power supply, interrupt the dc output side rather than the ac line side of the supply to avoid the additional delay of power supply turn-off.

The ac line of the dc output power supply should be fused.

Connect a set of master control relays in series with the dc power supplying the input and output circuits.

Place the main power disconnect switch where operators and maintenance personnel have quick and easy access to it. If you mount a disconnect switch inside the controller enclosure, place the switch operating handle on the outside of the enclosure, so that you can disconnect power without opening the enclosure.

Whenever any of the emergency-stop switches are opened, power to input and output devices should be removed.

When you use the master control relay to remove power from the external I/O circuits, power continues to be provided to the controller's power supply so that diagnostic indicators on the processor can still be observed.

The master control relay is not a substitute for a disconnect to the controller. It is intended for any situation where the operator must quickly de-energize I/O devices only. When inspecting or installing terminal connections, replacing output fuses, or working on

equipment within the enclosure, use the disconnect to shut off power to the rest of the system.

**TIP**

Do not control the master control relay with the controller. Provide the operator with the safety of a direct connection between an emergency-stop switch and the master control relay.

## Using Emergency-Stop Switches

When using emergency-stop switches, adhere to the following points:

- Do not program emergency-stop switches in the controller program. Any emergency-stop switch should turn off all machine power by turning off the master control relay.
- Observe all applicable local codes concerning the placement and labeling of emergency-stop switches.
- Install emergency-stop switches and the master control relay in your system. Make certain that relay contacts have a sufficient rating for your application. Emergency-stop switches must be easy to reach.
- In the following illustration, input and output circuits are shown with MCR protection. However, in most applications, only output circuits require MCR protection.

The following illustrations show the Master Control Relay wired in a grounded system.

**TIP**

In most applications input circuits do not require MCR protection; however, if you need to remove power from all field devices, you must include MCR contacts in series with input power wiring.

### Schematic (Using IEC Symbols)

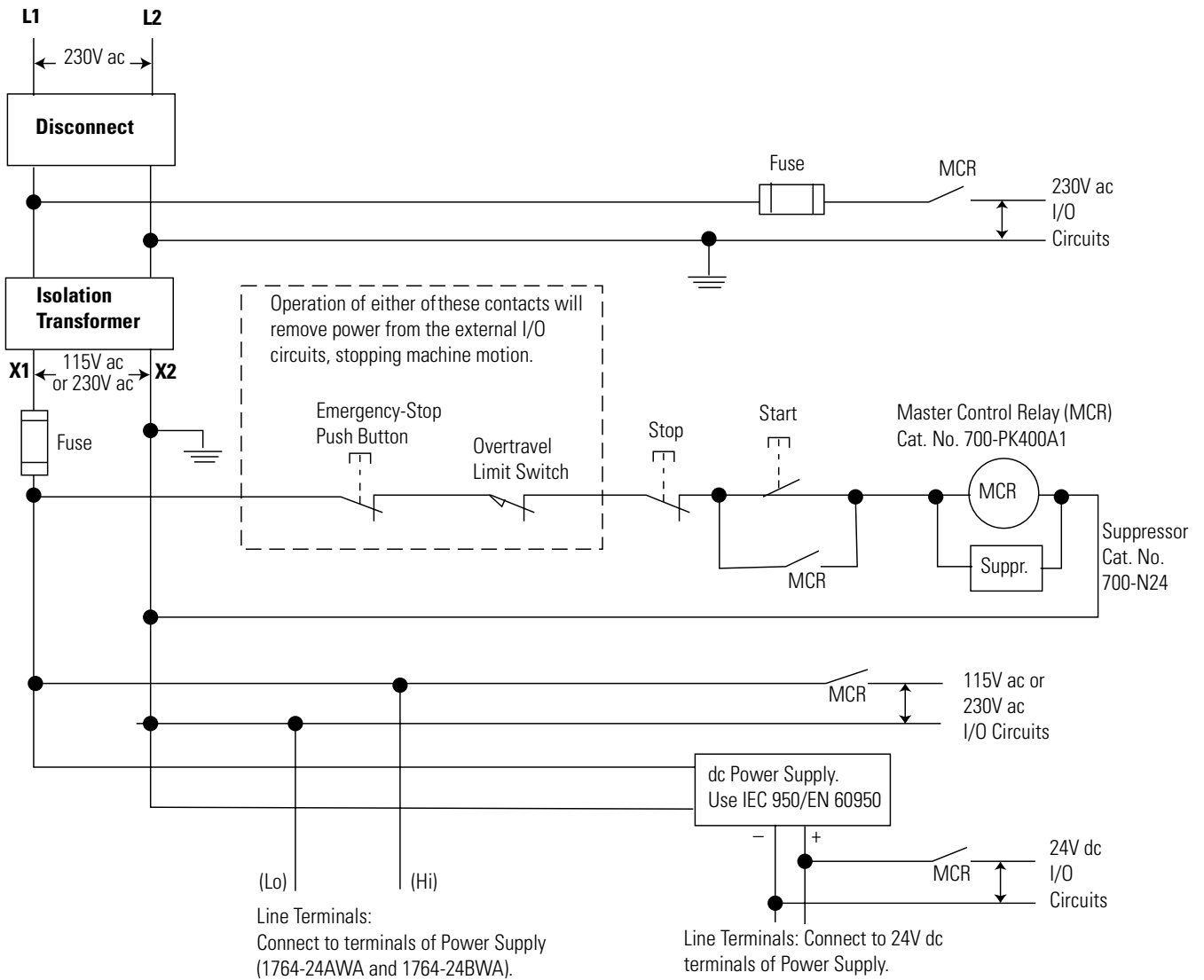

### Schematic (Using ANSI/CSA Symbols)

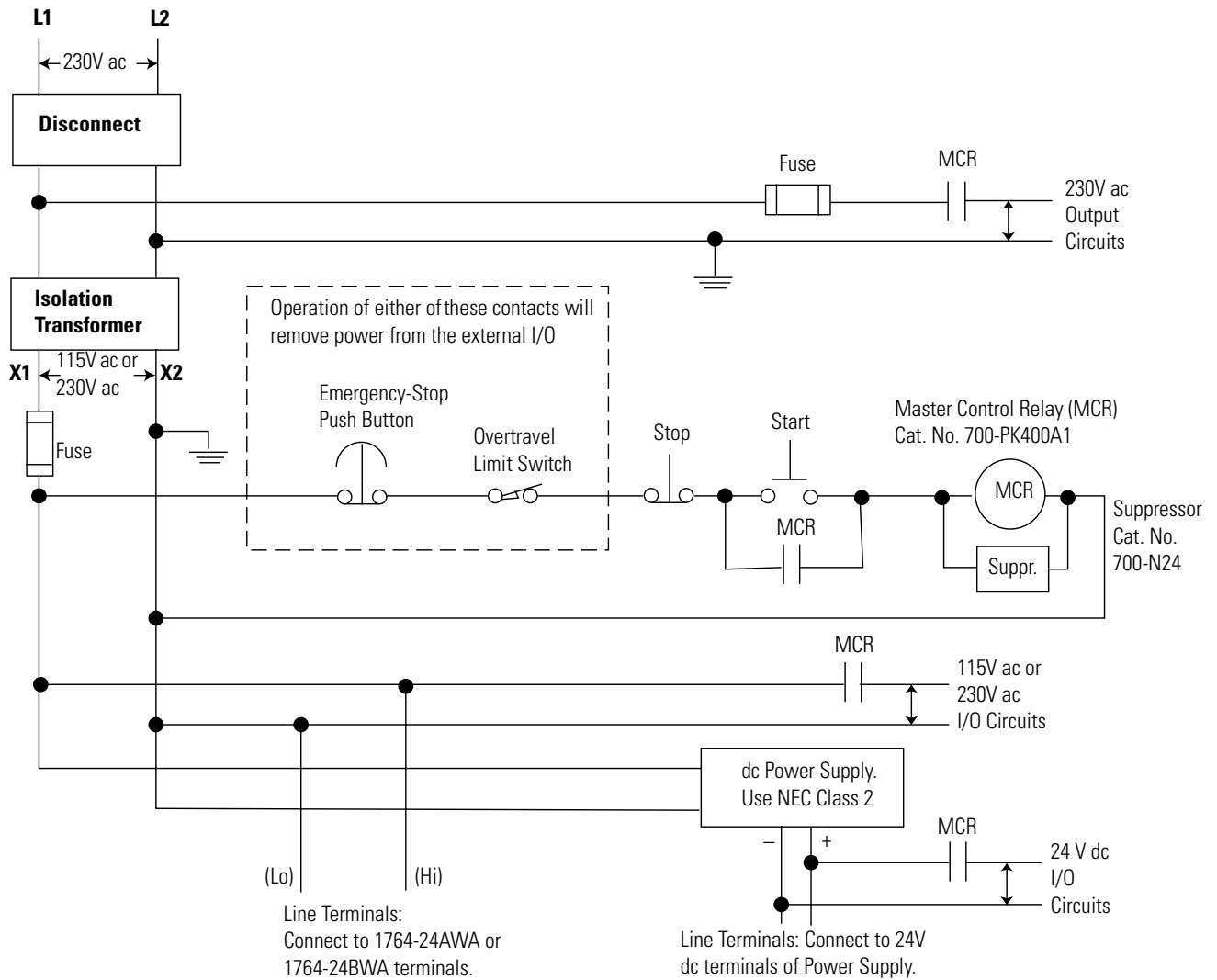

## Base Unit Mounting Dimensions

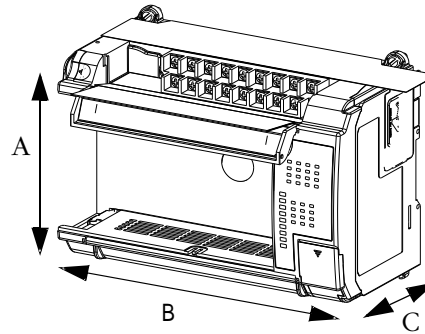

Dimension <sup>(1)</sup>	1764-24AWA	1764-24BWA	1764-28BXB
Height (A)	DIN latch open: 138 mm (5.43 in.), DIN latch closed: 118 mm (4.65 in.)		
Width (B)	168 mm (6.62 in.)		
Depth (C)	87 mm (3.43 in.)		

(1) See Controller Dimensions on page A-9 for more dimensional information.

## Controller Spacing

The base unit is designed to be mounted horizontally, with the Compact™ expansion I/O extending to the right of the base unit. Allow 50 mm (2 in.) minimum of space on all sides for adequate ventilation, as shown below.

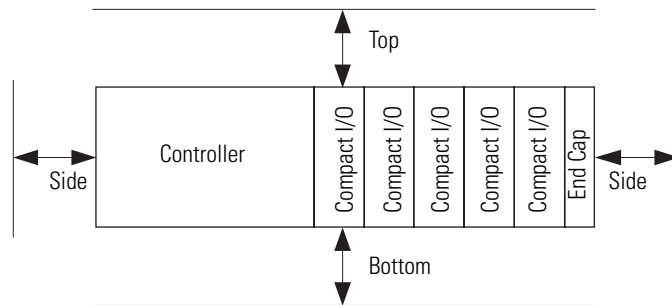

## Mounting the Controller

**ATTENTION**

Do not remove protective debris strips until after the base and all other equipment in the panel near the base is mounted and wiring is complete. The debris strips are there to prevent drill fragments, wire strands and other dirt from getting into the controller. Once wiring is complete, remove protective debris strips and install processor unit. Failure to remove strips before operating can cause overheating.

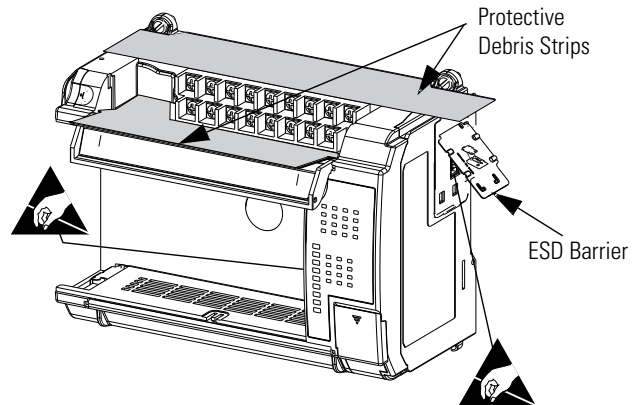
**ATTENTION**

Be careful of metal chips when drilling mounting holes for your controller or other equipment within the enclosure or panel. Drilled fragments that fall into the controller could cause damage. Do not drill holes above a mounted controller if the protective debris strips have been removed.

**ATTENTION**

Electrostatic discharge can damage semiconductor devices inside the base unit. Do not touch the connector pins or other sensitive areas.

**TIP**



If additional I/O modules are required for the application, remove the ESD barrier to install expansion I/O modules. A maximum of 16 I/O modules may be connected to the base. (See page 1-7 for system requirements.) The I/O module's current requirements and power consumption may further limit the number of modules connected to the base. See System Loading and Heat Dissipation on page F-1. An end cap terminator (catalog number 1769-ECR or 1769-ECL) is required at the end of the group of I/O modules attached to the base.

### Using a DIN Rail

The base unit and expansion I/O DIN rail latches lock in the open position so that an entire system can be easily attached to or removed from the DIN rail. The maximum extension of the latch is 15 mm (0.67 in.) in the open position. A flat-blade screw driver is required for removal of the base unit. The base can be mounted to EN50022-35x7.5 or EN50022-35x15 DIN rails. DIN rail mounting dimensions are shown below.

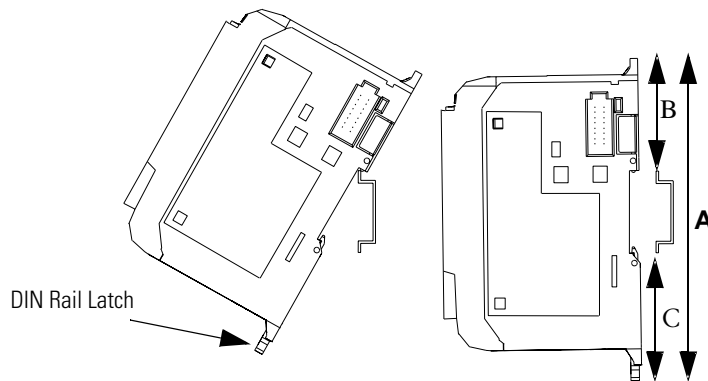

Dimension	Height
A	DIN latch open: 138 mm (5.43 in.), DIN latch closed: 118 mm (4.65 in.)
B	47.6 mm (1.875 in.)
C	47.6 mm (1.875 in) DIN latch closed 54.7 mm (2.16 in.) DIN latch open



To install your base unit on the DIN rail:

1. Mount your DIN rail. (Make sure that the placement of the base unit on the DIN rail meets the recommended spacing requirements, see Controller Spacing on page 2-12. Refer to the mounting template from the inside back cover of the *MicroLogix 1500 Programmable Controller Base Units Installation Instructions*, publication 1764-IN001.
2. Hook the top slot over the DIN rail.
3. While pressing the base unit down against the top of the rail, snap the bottom of the base unit into position. Ensure DIN latches are in the up (secured) position.
4. Leave the protective debris strip attached until you are finished wiring the base unit and any other devices.

To remove your base unit from the DIN rail:

1. Place a flat-blade screwdriver in the DIN rail latch at the bottom of the base unit.
2. Holding the base unit, pry downward on the latch until the latch locks in the open position. Repeat this procedure with the second latch. This releases the base unit from the DIN rail.

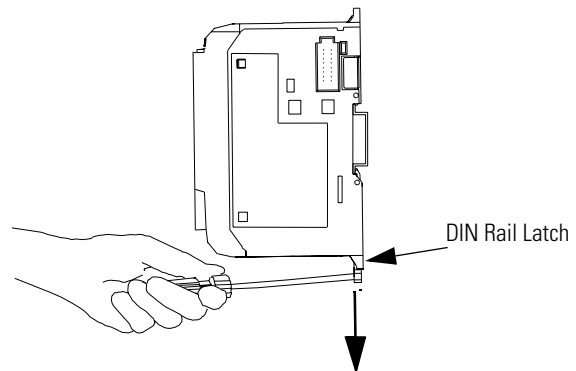

## Base Unit Panel Mounting

Mount to panel using #8 or M4 screws.

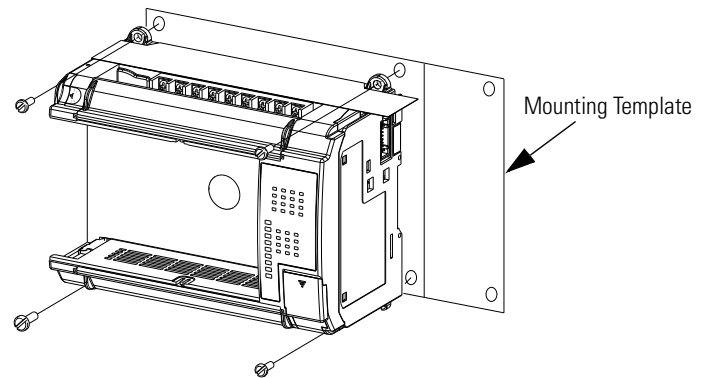

To install your base unit using mounting screws:

1. Remove the mounting template from the inside back cover of the *MicroLogix 1500 Programmable Controller Base Units Installation Instruction*, publication 1764-IN001.
2. Secure the template to the mounting surface. (Make sure your base unit is spaced properly, see Controller Spacing on page 2-12).
3. Drill holes through the template.
4. Remove the mounting template.
5. Mount the base unit.
6. Leave the protective debris strips attached until you are finished wiring the base unit and any other devices.

## Installing Controller Components

### Prevent Electrostatic Discharge

**ATTENTION**

Electrostatic discharge can damage integrated circuits or semiconductors if you touch bus connector pins. Follow these guidelines when you handle any module:

- Touch a grounded object to discharge static potential.
- Wear an approved wrist-strap grounding device.
- Do not touch the bus connector or connector pins.
- Do not touch circuit components inside the module.
- If available, use a static-safe work station.

When not in use, keep the module in its static-shield bag.

**ATTENTION**

Be sure the base unit is free of all metal fragments before removing protective debris strips and installing the processor unit. Failure to remove strips before operating can cause overheating.

### Processor

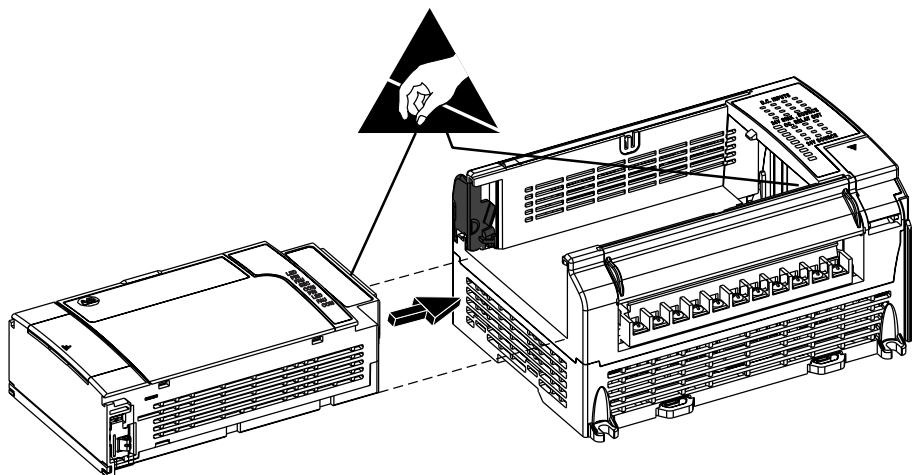

1. Be sure base unit power is off.
2. Slide the processor into the base unit using the guide rails for alignment.
3. Push until a click is heard. Be careful not to push on the connector when installing the 1764-LRP processor.

---

**IMPORTANT**

It is critical that the processor is fully engaged and locked into place.

---

4. Make sure the actuator is pushed closed.

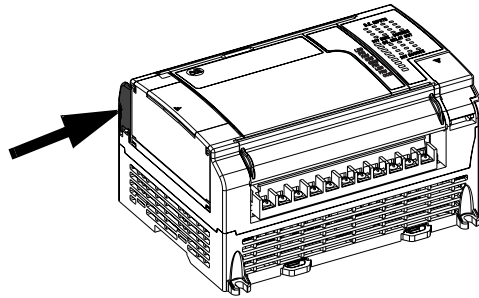

5. To remove the processor from the base unit, make sure base unit power is off. Push the actuator to the open position until the processor is ejected slightly. Once the processor has been ejected, it can be removed from the base unit.

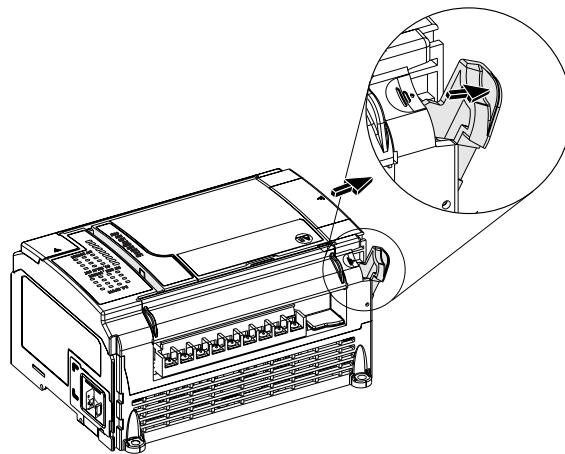

## Data Access Tool (DAT)

1. Remove cover from processor.

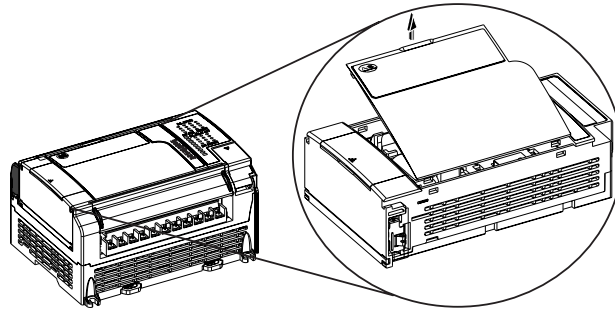

2. Holding the DAT in the proper orientation (as shown), place the DAT onto processor. Align DAT port on the processor with the plug on the DAT.

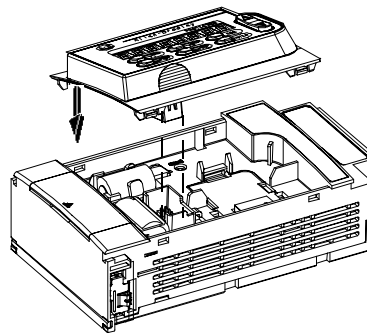

3. Firmly seat DAT on processor; make sure it seats into place.

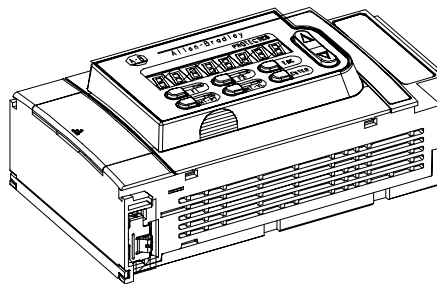

4. To remove DAT, grasp using finger areas and pull upward.

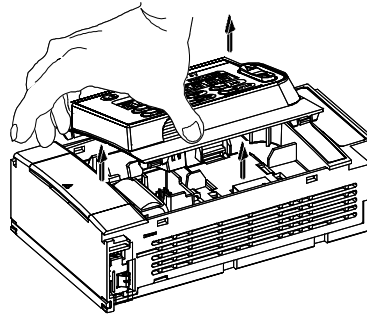

### Memory Module/Real-Time Clock

1. Remove the cover (or DAT if installed) from the processor as shown below.

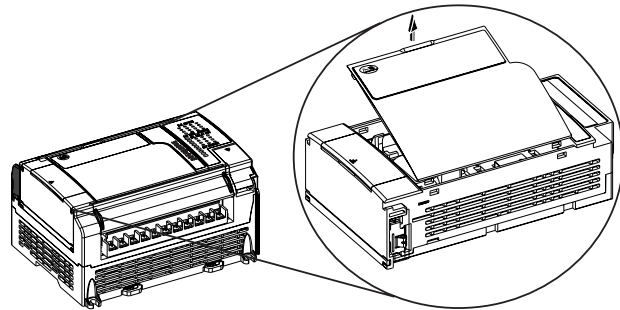

#### ATTENTION



Electrostatic discharge can damage semiconductor devices inside the base and processor units. Do not touch the connector pins or other sensitive areas.

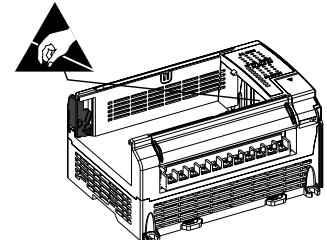
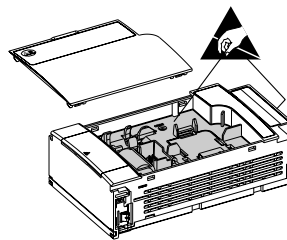

2. Align connector on the memory module with the connector pins on the processor.

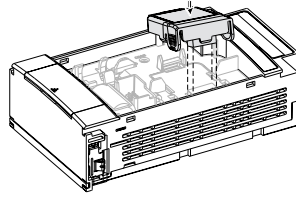

3. Firmly seat the memory module in the processor making sure the locking tabs click into place.

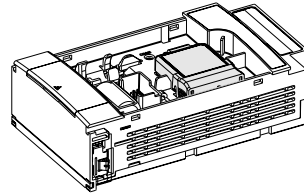

4. Replace the cover (or DAT if used).

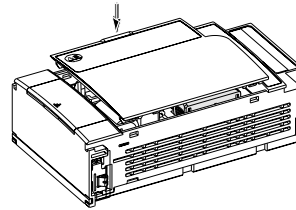

## Compact I/O

### *Attach and Lock Module (Module-to-Controller or Module-to-Module)*

A Compact I/O module can be attached to the controller or an adjacent I/O module before or after mounting to the panel or DIN rail. The module can be detached and replaced while the system is mounted to a panel or DIN rail.

---

#### **ATTENTION**



Remove power before removing or inserting an I/O module. When you remove or insert a module with power applied, an electrical arc may occur. An electrical arc can cause personal injury or property damage by:

- sending an erroneous signal to your system's field devices, causing the controller to fault
- causing an explosion in a hazardous environment

Electrical arcing causes excessive wear to contacts on both the module and its mating connector. Worn contacts may create electrical resistance, reducing product reliability.

---

---

#### **ATTENTION**



When attaching I/O modules, it is very important that they are securely locked together to ensure proper electrical connection.

---



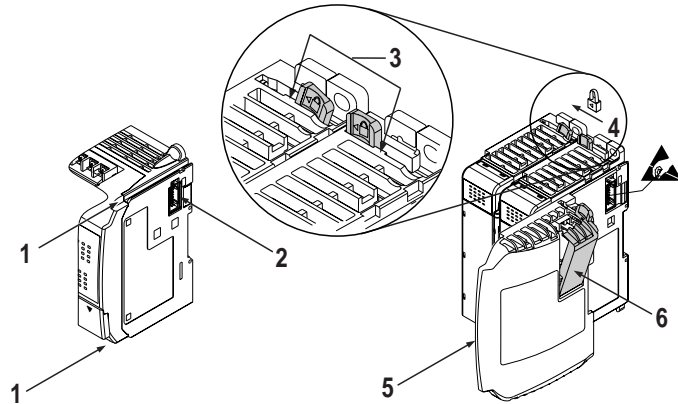

To attach and lock modules:

**TIP**

Remove ESD barrier when attaching I/O modules to a MicroLogix 1500 base unit.



1. Disconnect power.
2. Check that the bus lever of the module to be installed is in the unlocked (fully right) position.
3. Use the upper and lower tongue-and-groove slots (1) to secure the modules together (or to a controller).
4. Move the module back along the tongue-and-groove slots until the bus connectors (2) line up with each other.
5. Push the bus lever back slightly to clear the positioning tab (3). Use your fingers or a small screw driver.
6. To allow communication between the controller and module, move the bus lever fully to the left (4) until it clicks. Ensure it is locked firmly in place.

**ATTENTION**



When attaching I/O modules, it is very important that the bus connectors are securely locked together to ensure proper electrical connection.

7. Attach an end cap terminator (5) to the last module in the system by using the tongue-and-groove slots as before.
8. Lock the end cap bus terminator (6).

---

**IMPORTANT**

A 1769-ECR right end cap (or a 1769-ECL left end cap if I/O bank is located below the controller) must be used to terminate the end of the serial communication bus.

---

See Controller Dimensions on page A-9 for mounting dimensions.

## Wiring Your Controller

This chapter describes how to wire your controller. Topics include:

- wiring requirements
- using surge suppressors
- grounding guidelines
- sinking and sourcing circuits
- wiring diagrams, input voltage ranges, and output voltage ranges
- minimizing noise

### Wiring Requirements

Wire Type		Wire Size <sup>(1)</sup>	Wiring Torque
Solid	Cu-90°C (194°F)	#14 to #22 AWG	1.13 Nm (10 in-lb) rated 1.3 Nm (12 in-lb) maximum
Stranded	Cu-90°C (194°F)	#14 to #22 AWG	

(1) Two wires maximum per terminal screw.

#### ATTENTION



Be careful when stripping wires. Wire fragments that fall into the controller could cause damage. Once wiring is complete, be sure the base unit is free of all metal fragments before removing protective debris strips and installing the processor unit. Failure to remove strips before operating can cause overheating.

## Wiring Recommendation

---

**ATTENTION**

Before you install and wire any device, disconnect power to the controller system.

---

---

**ATTENTION**

Calculate the maximum possible current in each power and common wire. Observe all electrical codes dictating the maximum current allowable for each wire size. Current above the maximum ratings may cause wiring to overheat, which can cause damage.

*United States Only:* If the controller is installed within a potentially hazardous environment, all wiring must comply with the requirements stated in the National Electrical Code 501-4 (b).

---

- Allow for at least 50 mm. (2 in.) between I/O wiring ducts or terminal strips and the controller.
- Route incoming power to the controller by a path separate from the device wiring. Where paths must cross, their intersection should be perpendicular.

**TIP**

Do not run signal or communications wiring and power wiring in the same conduit. Wires with different signal characteristics should be routed by separate paths.

- Separate wiring by signal type. Bundle wiring with similar electrical characteristics together.
- Separate input wiring from output wiring.
- Label wiring to all devices in the system. Use tape, shrink-tubing, or other dependable means for labeling purposes. In addition to labeling, use colored insulation to identify wiring based on signal characteristics. For example, you may use blue for dc wiring and red for ac wiring.

### Wiring without Spade Lugs

When wiring without spade lugs, it is recommended to keep the finger-safe covers in place. Loosen the terminal screw and route the wires through the opening in the finger-safe cover. Tighten the terminal screw making sure the pressure plate secures the wire.

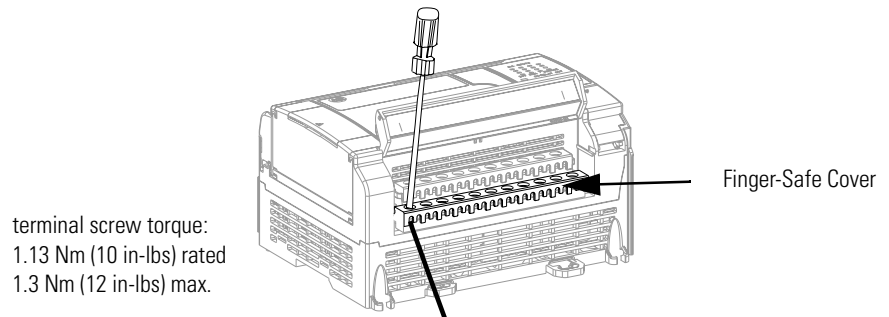

### Wiring with Spade Lugs

The diameter of the terminal screw head is 5.5 mm (0.220 in.). The input and output terminals of the MicroLogix 1500 base unit are designed for a 6.35mm (0.25 in.) wide spade (standard for #6 screw for up to 14 AWG) or a 4 mm (metric #4) fork terminal.

When using spade lugs, use a small, flat-blade screwdriver to pry the finger-safe cover from the terminal blocks as shown below. Then loosen the terminal screw.

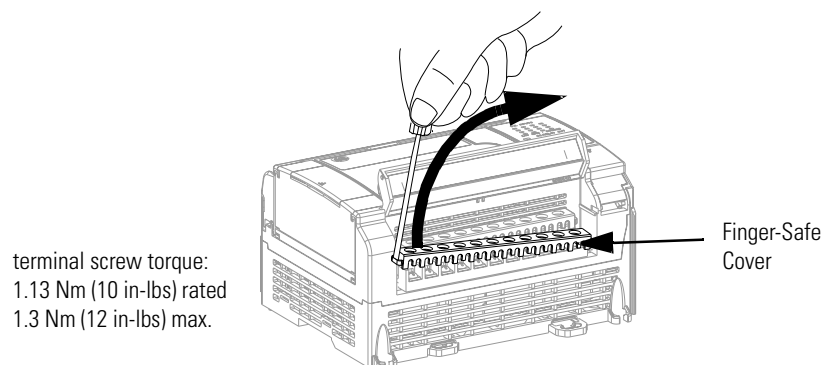

## Using Surge Suppressors

Inductive load devices, such as motor starters and solenoids, require the use of some type of surge suppression to protect and extend the operating life of the controller's output contacts. Switching inductive loads without surge suppression can *significantly* reduce the life expectancy of relay contacts. By adding a suppression device directly across the coil of an inductive device, you prolong the life of the output or relay contacts. You also reduce the effects of voltage transients and electrical noise from radiating into adjacent systems.

The following diagram shows an output with a suppression device. We recommend that you locate the suppression device as close as possible to the load device.

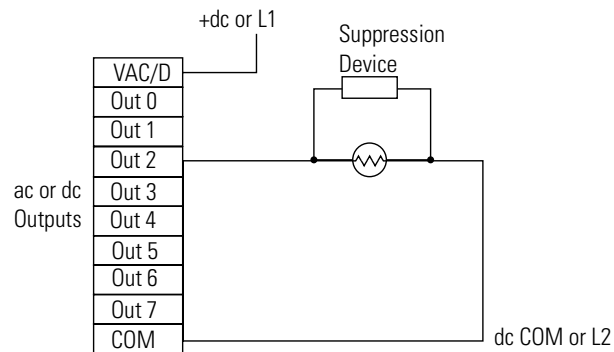

If the outputs are dc, we recommend that you use an 1N4004 diode for surge suppression, as shown below.

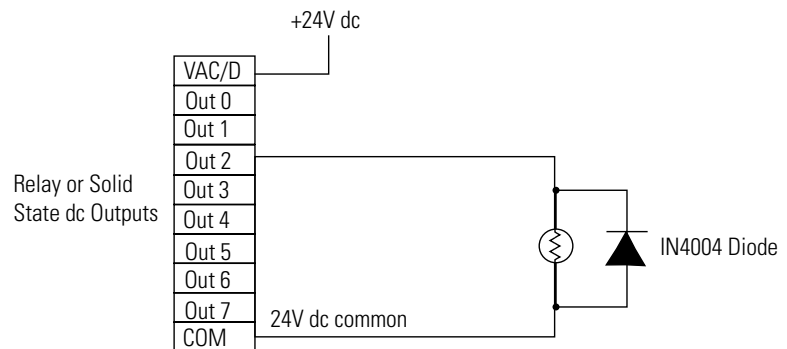

Suitable surge suppression methods for inductive ac load devices include a varistor, an RC network, or an Allen-Bradley surge suppressor, all shown below. These components must be appropriately rated to suppress the switching transient characteristic of the particular inductive device. See the table on page 3-6 for recommended suppressors.

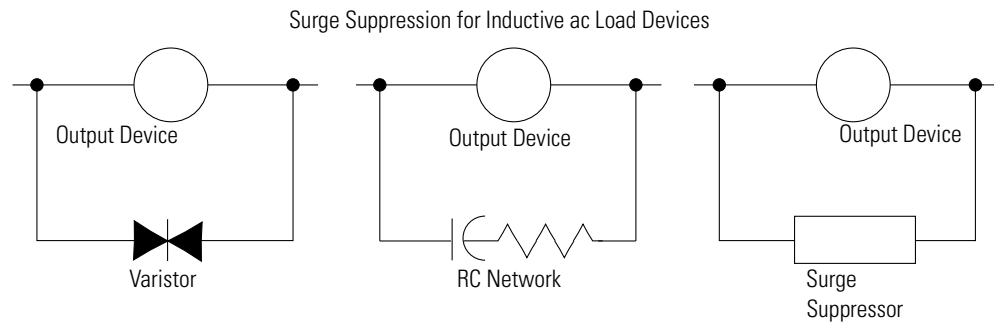

If you connect an expansion I/O triac output to control an inductive load, we recommend that you use varistors to suppress noise. Choose a varistor that is appropriate for the application. The suppressors we recommend for triac outputs when switching 120V ac inductive loads are a Harris MOV, part number V175 LA10A, or an Allen-Bradley MOV, catalog number 599-K04 or 599-KA04. Consult the varistor manufacturer's data sheet when selecting a varistor for your application.

For inductive dc load devices, a diode is suitable. A 1N4004 diode is acceptable for most applications. A surge suppressor can also be used. See the table on page 3-6 for recommended suppressors.

As shown in the illustration below, these surge suppression circuits connect directly across the load device.

Surge Suppression for Inductive dc Load Devices

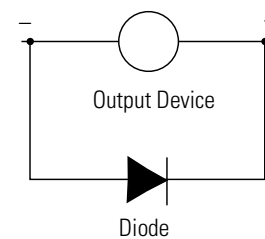

(A surge suppressor can also be used.)

## Recommended Surge Suppressors

Use the Allen-Bradley surge suppressors shown in the following table for use with relays, contactors, and starters.

Suppressor Device	Coil Voltage	Catalog Number
Bulletin 509 Motor Starter Bulletin 509 Motor Starter	120V ac 240V ac	599-K04 <sup>(1)</sup> 599-KA04 <sup>(1)</sup>
Bulletin 100 Contactor Bulletin 100 Contactor	120V ac 240V ac	199-FSMA1 <sup>(2)</sup> 199-FSMA2 <sup>(2)</sup>
Bulletin 709 Motor Starter	120V ac	1401-N10
Bulletin 700 Type R, RM Relays	ac coil	None Required
Bulletin 700 Type R Relay Bulletin 700 Type RM Relay	12V dc 12V dc	199-FSMA9
Bulletin 700 Type R Relay Bulletin 700 Type RM Relay	24V dc 24V dc	199-FSMA9
Bulletin 700 Type R Relay Bulletin 700 Type RM Relay	48V dc 48V dc	199-FSMA9
Bulletin 700 Type R Relay Bulletin 700 Type RM Relay	115-125V dc 115-125V dc	199-FSMA10
Bulletin 700 Type R Relay Bulletin 700 Type RM Relay	230-250V dc 230-250V dc	199-FSMA11
Bulletin 700 Type N, P, or PK Relay	150V max, ac or DC	700-N24 <sup>(2)</sup>
Miscellaneous electromagnetic devices limited to 35 sealed VA	150V max, ac or DC	700-N24 <sup>(2)</sup>

(1) Varistor – Not recommended for use on relay outputs.

(2) RC Type – Do not use with triac outputs.

## Grounding the Controller

In solid-state control systems, grounding and wire routing helps limit the effects of noise due to electromagnetic interference (EMI). Run the ground connection from the ground screw of the base unit to the electrical panel's ground bus prior to connecting any devices. Use AWG #14 wire. This connection must be made for safety purposes.



This product is intended to be mounted to a well grounded mounting surface such as a metal panel. Refer to the *Industrial Automation Wiring and Grounding Guidelines*, publication 1770-4.1, for additional information. Additional grounding connections from the mounting tabs or DIN rail, if used, are not required unless the mounting surface cannot be grounded. You must also provide an acceptable grounding path for each device in your application.

**TIP**

It is recommended to use all four mounting positions for panel mounting installation.

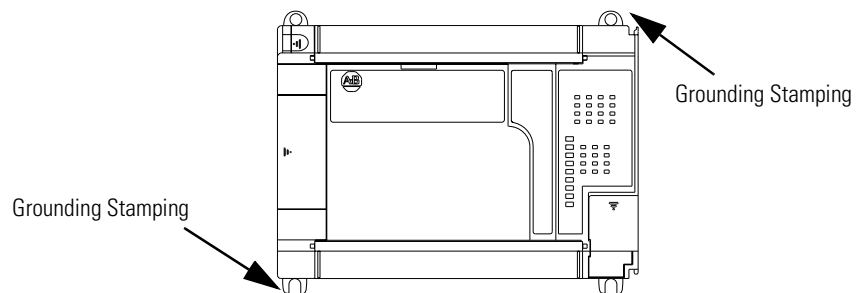
**TIP**

This  symbol denotes a protective earth ground terminal which provides a low impedance path between electrical circuits and earth for safety purposes and provides noise immunity improvement. This connection must be made for safety purposes

**ATTENTION**

Remove the protective debris strips before applying power to the controller. Failure to remove the strips may cause the controller to overheat.



## Wiring Diagrams

This section shows the wiring diagrams for the MicroLogix 1500 controllers. Controllers with dc inputs can be wired as either sinking or sourcing configuration. (Sinking and sourcing does not apply to ac inputs.) See pages 3-12 through 3-15 for sinking and sourcing wiring diagrams.

**TIP**



This  symbol denotes a protective earth ground terminal which provides a low impedance path between electrical circuits and earth for safety purposes and provides noise immunity improvement. This connection must be made for safety purposes.

### Miswiring - 1764-28BxB Only

The following table shows miswiring conditions and the consequences of improper wiring:

Condition	Result
Operating with Voltage Less than 20.4V dc	This will not damage the base unit. The base unit may not power up.
	<b>IMPORTANT</b> This is not recommended. You must verify that the line voltage remains within specified limits.
Reverse Wiring of the Line Terminals (0 to 30V dc)	Reverse wiring will not damage the base unit. The base unit will not power up.
Applied Voltage Level Exceeds the Published Recommended Value (i.e. applying 120V ac to 240V ac)	Exceeding the published recommended voltage may result in permanent damage to the base unit.

## Terminal Block Layouts

The base unit terminal block layouts are shown below. The shading on the labels indicates how the terminals are grouped. A detail of the groupings is shown in the table following the terminal block layouts.

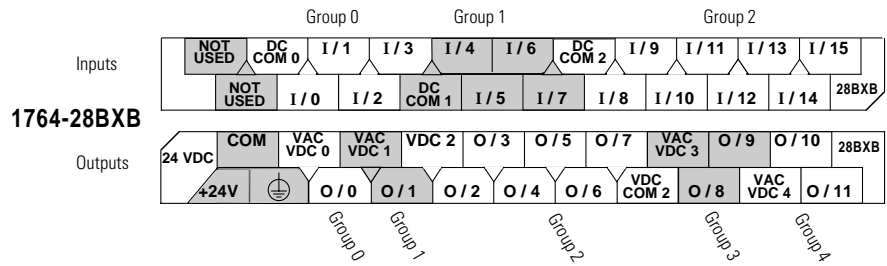
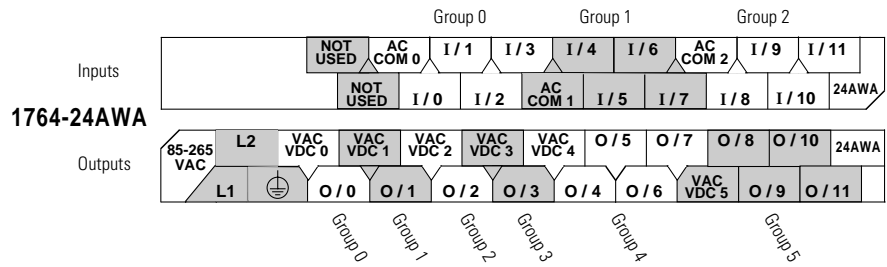
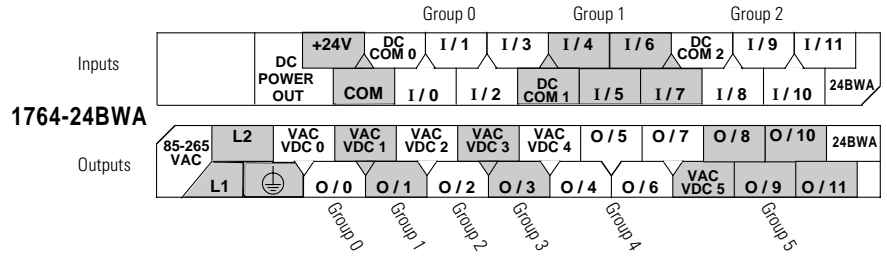

### Terminal Groupings

Controller	Inputs		
	Input Group	Common Terminal	Input Terminal
<b>1764-24BWA</b>	Group 0	DC COM 0	I/0 through I/3
	Group 1	DC COM 1	I/4 through I/7
	Group 2	DC COM 2	I/8 through I/11
<b>1764-24AWA</b>	Group 0	AC COM 0	I/0 through I/3
	Group 1	AC COM 1	I/4 through I/7
	Group 2	AC COM 2	I/8 through I/11
<b>1764-28BXB</b>	Group 0	DC COM 0	I/0 through I/3
	Group 1	DC COM 1	I/4 through I/7
	Group 2	DC COM 2	I/8 through I/15

Controller	Outputs		
	Output Group	Voltage Terminal	Output Terminal
<b>1764-24BWA</b>	Group 0	VAC/VDC 0	O/0
	Group 1	VAC/VDC 1	O/1
	Group 2	VAC/VDC 2	O/2
	Group 3	VAC/VDC 3	O/3
	Group 4	VAC/VDC 4	O/4 through O/7
	Group 5	VAC/VDC 5	O/8 through O/11
<b>1764-24AWA</b>	Group 0	VAC/VDC 0	O/0
	Group 1	VAC/VDC 1	O/1
	Group 2	VAC/VDC 2	O/2
	Group 3	VAC/VDC 3	O/3
	Group 4	VAC/VDC 4	O/4 through O/7
	Group 5	VAC/VDC 5	O/8 through O/11
<b>1764-28BXB</b>	Group 0	VAC/VDC 0	O/0
	Group 1	VAC/VDC 1	O/1
	Group 2	VDC 2, VDC COM 2	O/2 through O/7
	Group 3	VAC/VDC 3	O/8 and O/9
	Group 4	VAC/VDC 4	O/10 and O/11

### Sinking and Sourcing Input Circuits

Any of the MicroLogix 1500 DC embedded input groups can be configured as sinking or sourcing depending on how the DC COM is wired on the group. See pages 3-12 through 3-15 for sinking and sourcing wiring diagrams.

Type	Definition
Sinking Input <i>connection of a PNP sourcing device</i>	The input energizes when high-level voltage is applied to the input terminal (active high). Connect the power supply VDC (-) to the DC COM terminal.
Sourcing Input <i>connection of an NPN sinking device</i>	The input energizes when low-level voltage is applied to the input terminal (active low). Connect the power supply VDC (+) to the DC COM terminal.

## 1764-24AWA Wiring Diagram

### Input Terminals

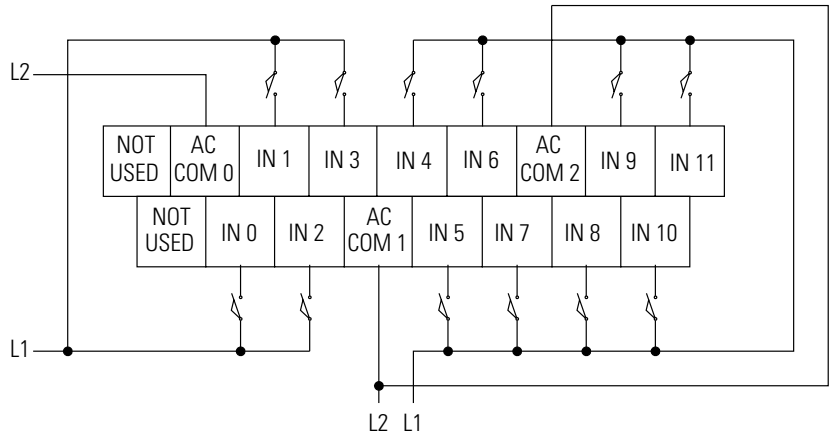

"NOT USED" terminals are not intended for use as connection points.

### Output Terminals

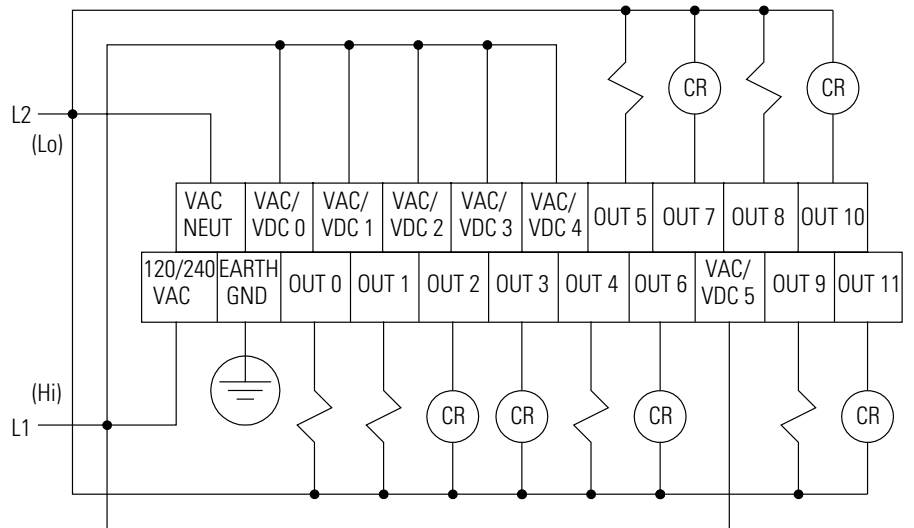

### 1764-24BWA Wiring Diagram with Sinking Inputs

#### Input Terminals

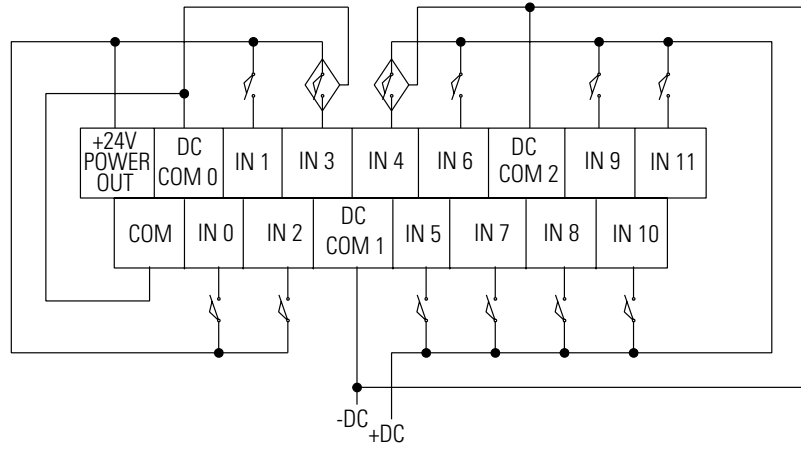

#### Output Terminals

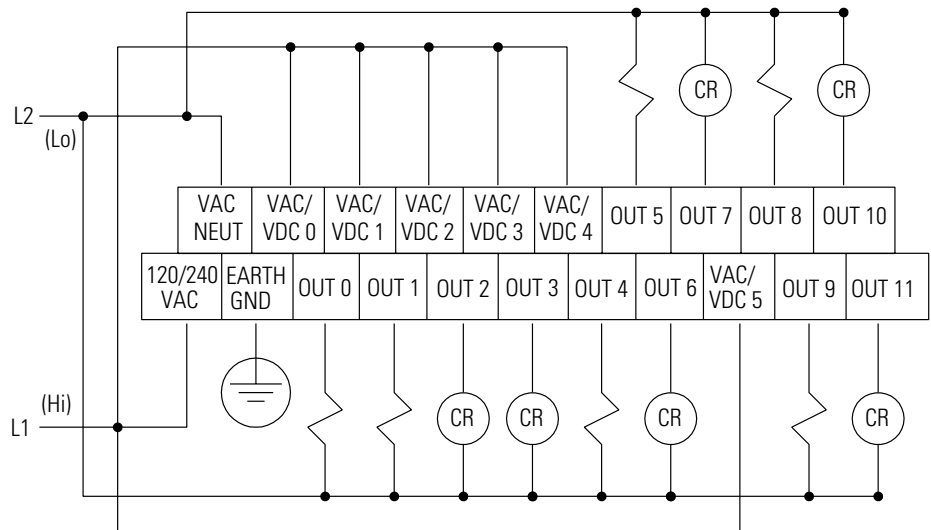

### 1764-24BWA Wiring Diagram with Sourcing Inputs

#### Input Terminals

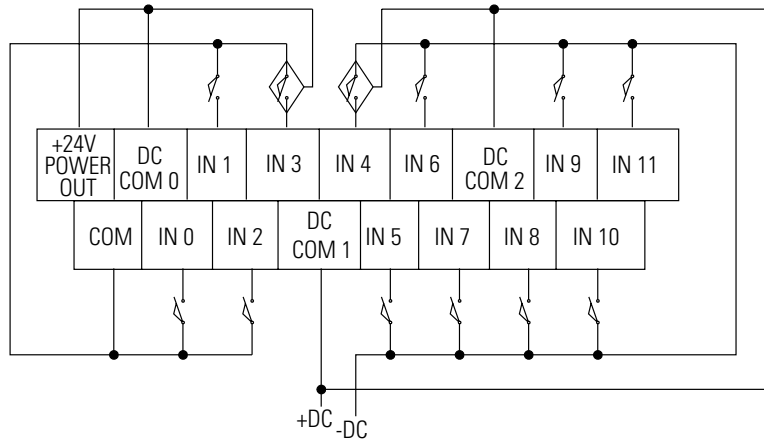

#### Output Terminals

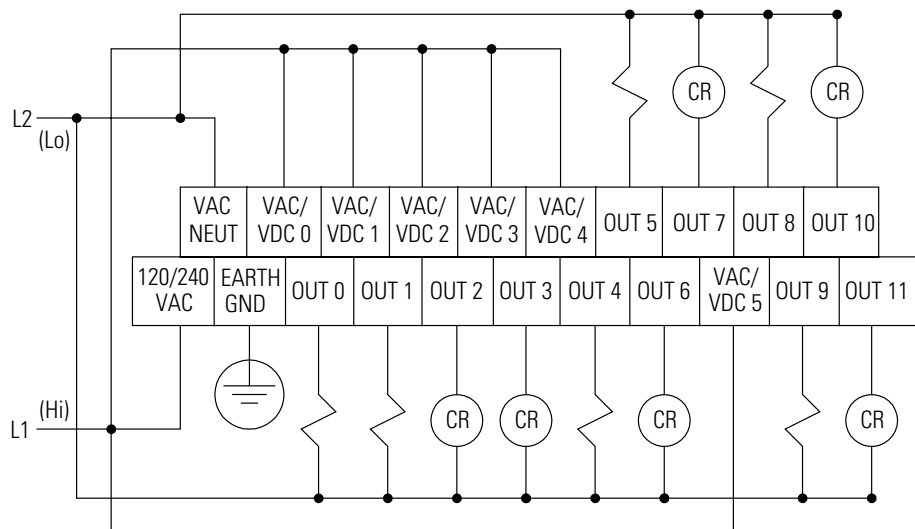

## 1764-28BXB Wiring Diagram with Sinking Inputs

### Input Terminals

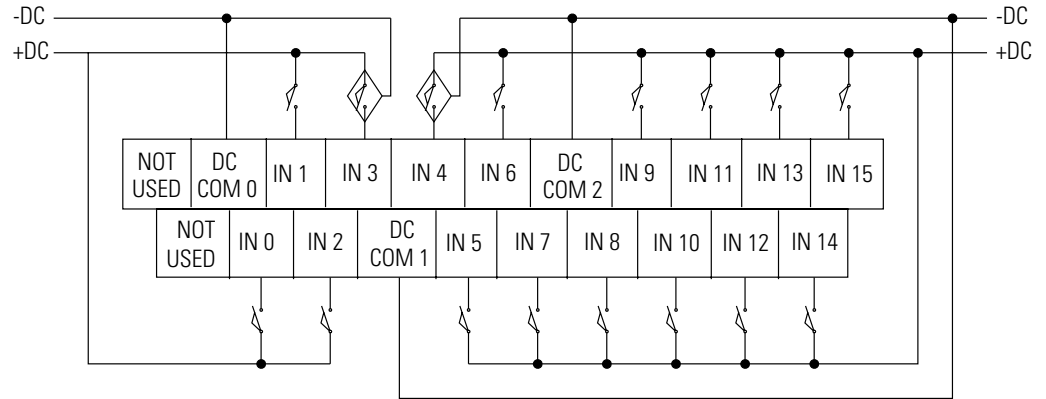

"NOT USED" terminals are not intended for use as connection points.

### Output Terminals (FET Outputs Are Sourcing Only)

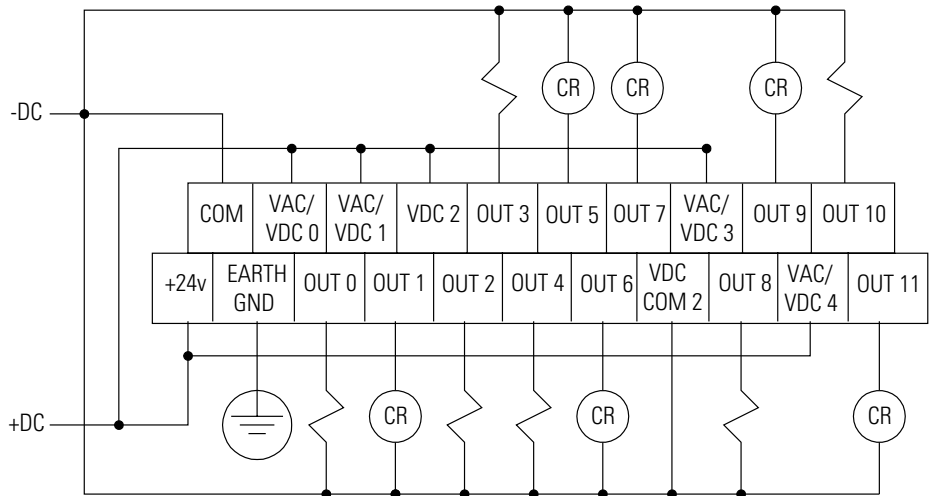



## 1764-28BXB Wiring Diagram with Sourcing Outputs

### Input Terminals

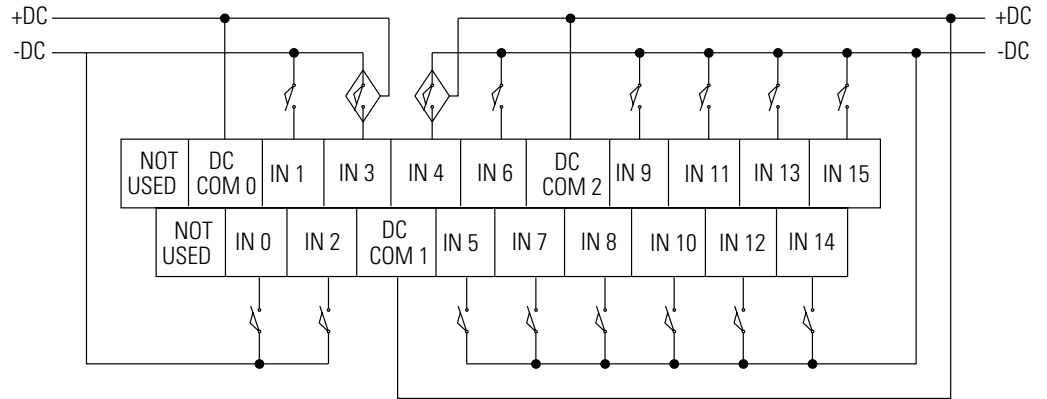

"NOT USED" terminals are not intended for use as connection points.

### Output Terminals (FET Outputs Are Sourcing Only)

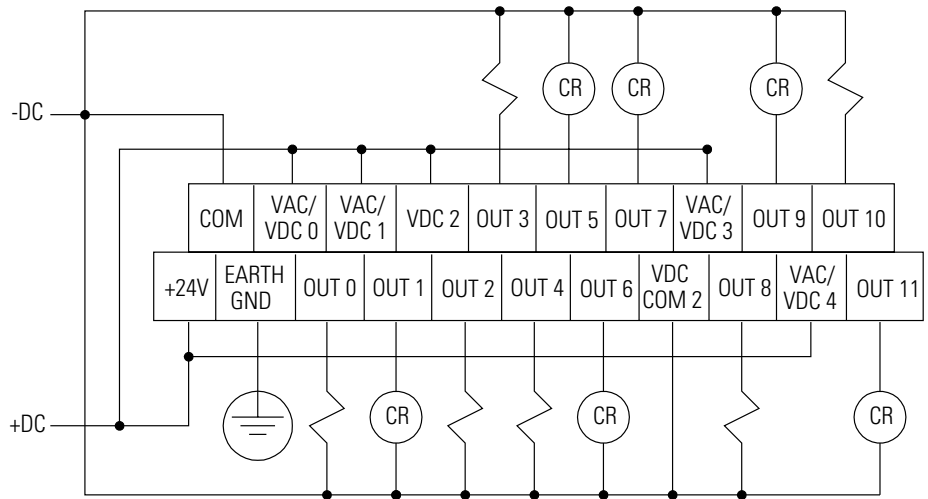

## Controller I/O Wiring

### Minimizing Electrical Noise

Because of the variety of applications and environments where controllers are installed and operating, it is impossible to ensure that all environmental noise will be removed by input filters. To help reduce the effects of environmental noise, install the MicroLogix 1500 system in a properly rated (i.e. NEMA) enclosure. Make sure that the MicroLogix 1500 system is properly grounded.

A system may malfunction may occur due to a change in the operating environment after a period of time. We recommend periodically checking system operation, particularly when new machinery or other noise sources are installed near the Micrologix 1500 system.

### Transistor Output Transient Pulses

---

**ATTENTION**

A brief transient current pulse may flow through transistor outputs if the external supply voltage is suddenly applied at the V<sub>dc</sub> and V<sub>dc</sub> com terminals (e.g. via the master control relay). It is a fast rate-of-change of voltage at the terminals that causes the pulse. This condition is inherent in transistor outputs and is common to solid state devices. The transient pulses may occur regardless of whether the controller is powered or running.

---

The transient energy is dissipated in the load, and the pulse duration is longer for loads with high impedance. The graph below illustrates the relation between pulse duration and load current. Power-up transients will not exceed the times shown in the graph. For most applications the pulse energy is not sufficient to energize the load.

To reduce the possibility of inadvertent operation of devices connected to transistor outputs, consider adding an external resistor in parallel to the load to increase the on-state load current. The duration of the transient pulse is reduced when the on-state load current is increased or the load impedance is decreased.

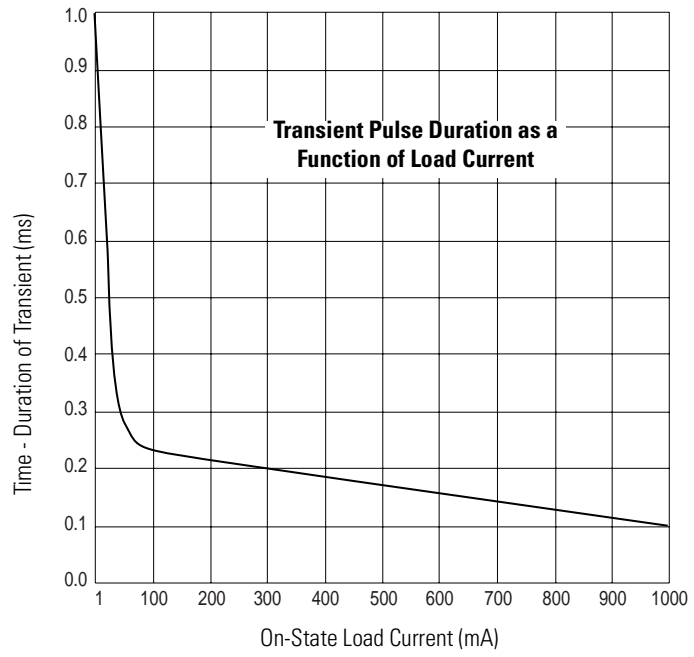



## Communication Connections

This chapter describes how to set up communications for your control system. The method you use and cabling required depend on your application. This chapter also describes how the controller establishes communication with the appropriate network. Topics include:

- Default Communication Configuration
- Communications Toggle Push Button
- Connecting to the RS-232 Port
- Connecting to a DH-485 Network
- Connecting to DeviceNet
- Connecting to Ethernet

### ATTENTION

All devices communicating within a network, must use the same protocol.



## Default Communication Configuration

The MicroLogix 1500 has the following default communication configuration.

**Table 4.1 DF1 Full-Duplex Configuration Parameters**

Parameter	Default
Baud Rate	19.2K
Parity	none
Source ID (Node Address)	1
Control Line	no handshaking
Error Detection	CRC
Embedded Responses	auto detect
Duplicate Packet (Message) Detect	enabled
ACK Timeout	50 counts
NAK retries	3 retries
ENQ retries	3 retries
Stop Bits	1

**TIP**



The default configuration is present when:

- The controller is powered-up for the first time.
- The communications toggle push button specifies default communications (the DCOMM LED is on).
- An OS upgrade is completed.

For more information about communications, see Understanding Communication Protocols on page E-1.

## Communications Toggle Push Button

The Communications Toggle Push Button is located on the processor. You must remove processor door or DAT to access the Communications Toggle Push Button.

Use the Communications Toggle Push Button to change from the user-defined communication configuration to the default communications configuration and back. The Default Communications (DCOMM) LED operates to show when the controller is in the default communications mode (settings shown on page 4-1).

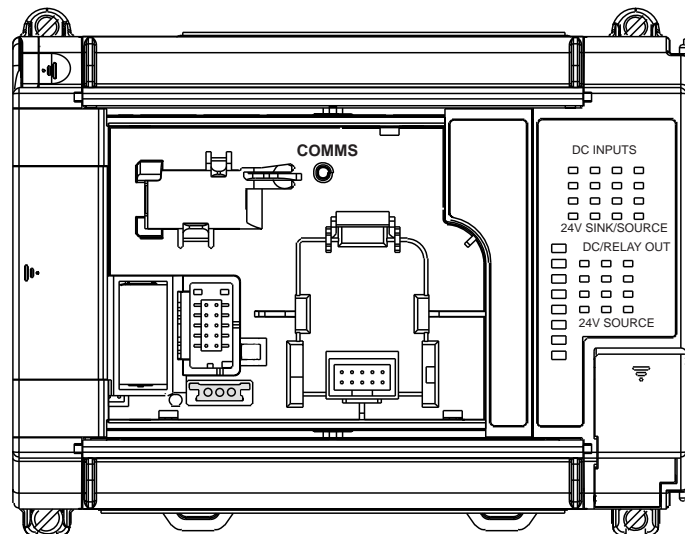

**TIP**



The Communication Toggle Push Button must be pressed and held for two seconds to activate.

The Communication Toggle Push Button only affects the communication configuration of Channel 0.

## Connecting to the RS-232 Port

### DF1 Full-Duplex Communication Parameters

When a communication channel is configured for DF1 Full-Duplex, the following parameters can be changed.

**Table 4.2 DF1 Full-Duplex Configuration Parameters**

Parameter	Options	Default
Baud Rate	300, 600, 1200, 2400, 4800, 9600, 19.2K, 38.4K	19.2K
Parity	none, even	none
Source ID (Node Address)	0 to 254 decimal	1
Control Line	no handshaking, Full-Duplex modem handshaking	no handshaking
Error Detection	CRC, BCC	CRC
Embedded Responses	auto-detect, enabled	auto detect
Duplicate Packet (Message) Detect	enabled, disabled	enabled
ACK Timeout	1 to 65535 counts (20 ms increments)	50 counts
NAK retries	0 to 255	3 retries
ENQ retries	0 to 255	3 retries
Stop Bits	not a setting, always 1	1

### Making a DF1 Full-Duplex Point-to-Point Connection

You can connect the MicroLogix 1500 programmable controller to your personal computer using a serial cable from your personal computer's serial port to the controller, as shown in the illustrations below.

#### ATTENTION



Chassis ground, internal 24V ground, user 24V dc ground, and RS-232 ground are internally connected. You must connect the chassis ground terminal screw to ground prior to connecting any devices. It is important that you understand your personal computer's grounding system before connecting to the controller. An optical isolator, such as the 1761-NET-AIC, is recommended between the controller and your personal computer when using Channel 0. An isolator is not required when using Channel 1 (1764-LRP).

### Channel 0

We recommend using an Advanced Interface Converter (AIC+), catalog number 1761-NET-AIC, or similar optical isolator, as shown below. See page 4-16 for specific AIC+ cabling information.

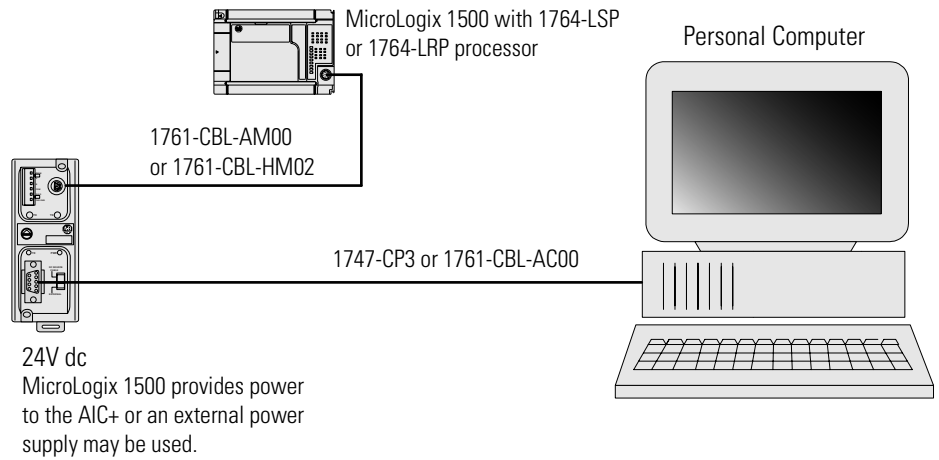

### Channel 1

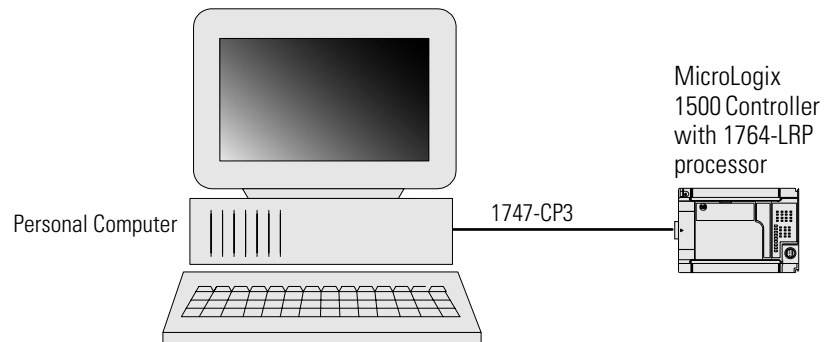



## Using a Modem

You can use modems to connect a personal computer to one MicroLogix 1500 controller (using DF1 Full-Duplex protocol), or to multiple controllers (using DF1 Half-Duplex protocol), or Modbus Slave RTU protocol, as shown in the following illustration. Do not use DH-485 protocol through modems under any circumstance. (See Using Modems with MicroLogix 1500 Programmable Controllers on page E-3 for information on types of modems you can use with the MicroLogix controllers.)

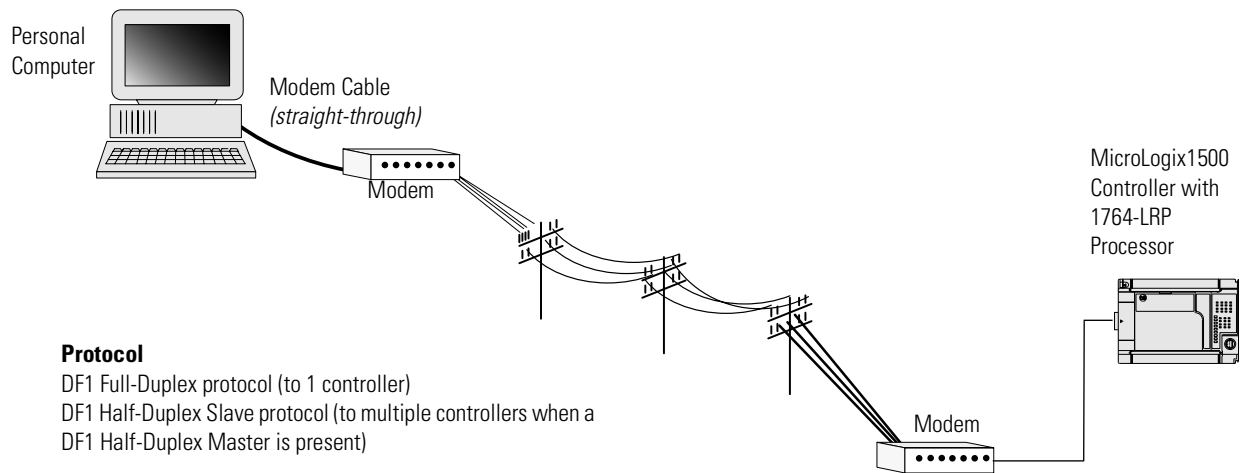

## Isolated Modem Connection

We recommend using an AIC+, catalog number 1761-NET-AIC, as your optical isolator for Channel 0. See page 4-16 for specific AIC+ cabling information. Using an AIC+ to isolate the modem is illustrated below:

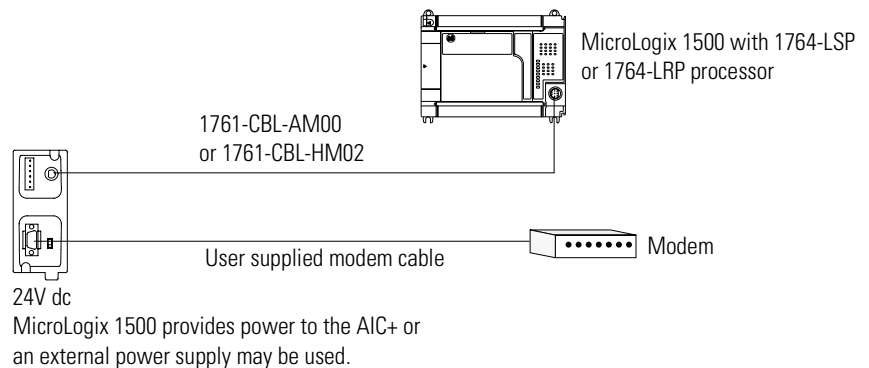

### Constructing Your Own Modem Cable

If you construct your own modem cable, the maximum cable length is 15.24 m (50 ft) with a 25-pin or 9-pin connector. Refer to the following typical pinout for constructing a *straight-through* cable:

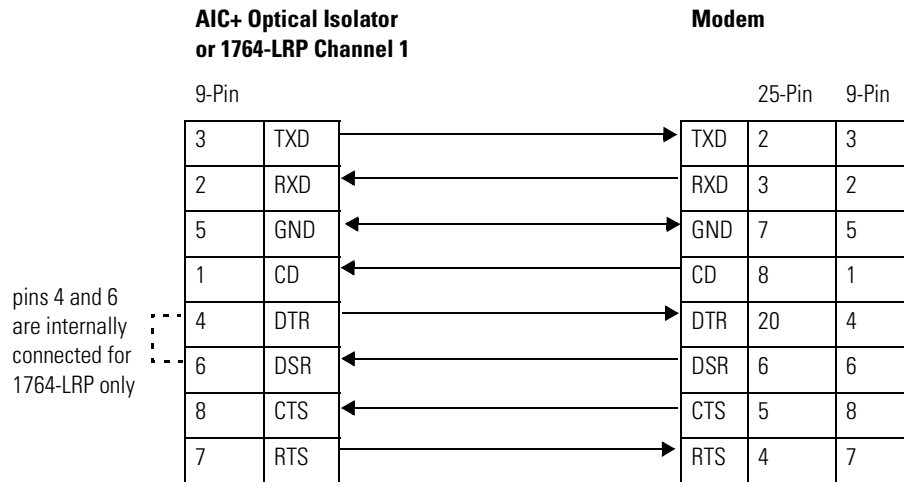

### Constructing Your Own Null Modem Cable

If you construct your own null modem cable, the maximum cable length is 15.24m (50 ft) with a 25-pin or 9-pin connector. Refer to the following typical pinout:

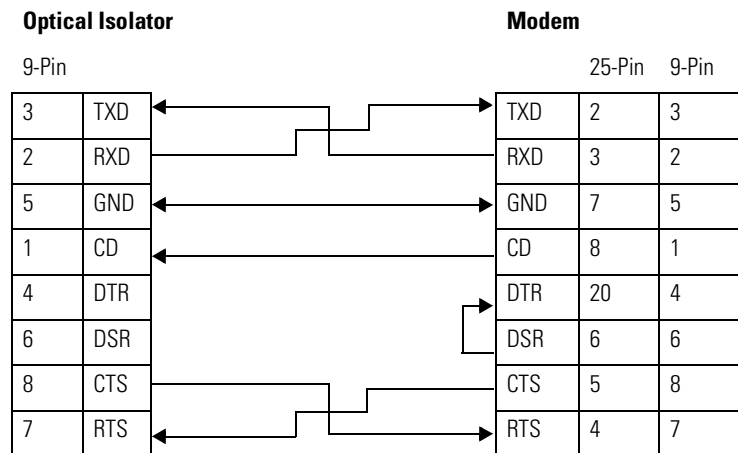

## Connecting to a DF1 Half-Duplex Network

When a communication port is configured for DF1 Half-Duplex Slave, available parameters include:

**Table 4.3 DF1 Half-Duplex Configuration Parameters**

Parameter	Options
Baud Rate	300, 600, 1200, 2400, 4800, 9600, 19.2K, 38.4K
Parity	none, even
Source ID (Node Address)	0 to 254 decimal
Control Line	no handshaking, handshaking
Error Detection	CRC, BCC
EOT Suppression	enabled, disabled When EOT Suppression is enabled, the slave does not respond when polled if no message is queued. This saves modem transmission power and time when there is no message to transmit.
Duplicate Packet (Message) Detect	enabled, disabled Detects and eliminates duplicate responses to a message. Duplicate packets may be sent under noisy communication conditions if the sender's Message Retries are not set to 0.
Poll Timeout (x20 ms)	0 to 65535 (can be set in 20 ms increments) Poll Timeout only applies when a slave device initiates a MSG instruction. It is the amount of time that the slave device waits for a poll from the master device. If the slave device does not receive a poll within the Poll Timeout, a MSG instruction error is generated, and the ladder program needs to requeue the MSG instruction. If you are using a MSG instruction, it is recommended that a Poll Timeout value of zero not be used. Poll Timeout is disabled when set to zero.
RTS Off Delay (x20 ms)	0 to 65535 (can be set in 20 ms increments) Specifies the delay time between when the last serial character is sent to the modem and when RTS is deactivated. Gives the modem extra time to transmit the last character of a packet.
RTS Send Delay (x20 ms)	0 to 65535 (can be set in 20 ms increments) Specifies the time delay between setting RTS until checking for the CTS response. For use with modems that are not ready to respond with CTS immediately upon receipt of RTS.
Message Retries	0 to 255 Specifies the number of times a slave device attempts to resend a message packet when it does not receive an ACK from the master device. For use in noisy environments where message packets may become corrupted in transmission.
Pre Transmit Delay (x1 ms)	0 to 65535 (can be set in 1 ms increments) <ul style="list-style-type: none"> <li>When the Control Line is set to <i>no handshaking</i>, this is the delay time before transmission. Required for 1761-NET-AIC physical Half-Duplex networks. The 1761-NET-AIC needs delay time to change from transmit to receive mode.</li> <li>When the Control Line is set to <i>DF1 Half-Duplex Modem</i>, this is the minimum time delay between receiving the last character of a packet and the RTS assertion.</li> </ul>

### DF1 Half-Duplex Master-Slave Network

Use this diagram for DF1 Half-Duplex Master-Slave protocol without hardware handshaking.

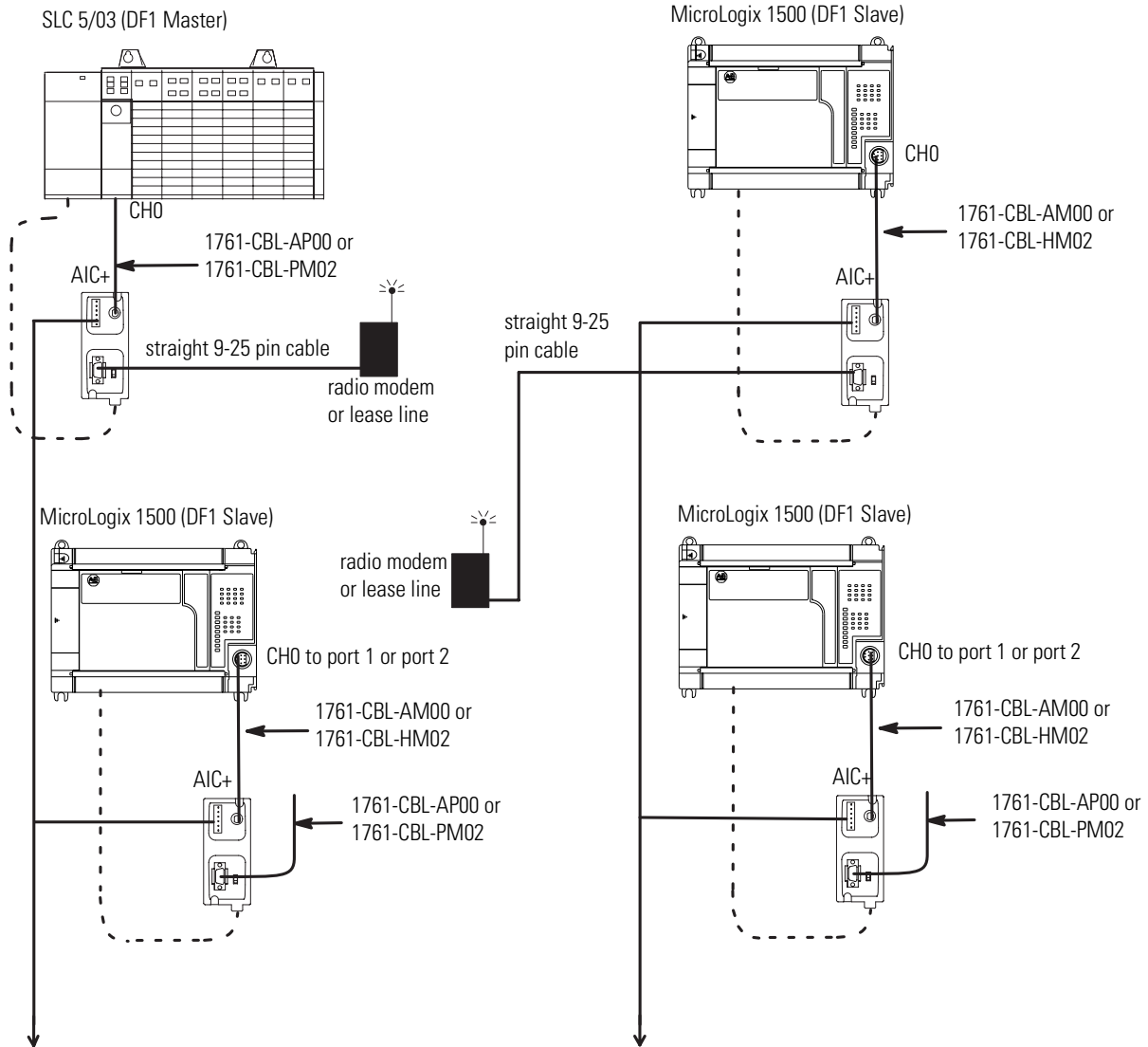

**REFERENCE: AIC+ Port Identification**

Port 3: RS-485  Port 2: mini-DIN 8 RS-232

Port 1: DB-9 RS-232 

*DF1 Half-Duplex Network (Using PC and Modems)*

Rockwell Software RSLinx 2.0 (or higher), SLC 5/03, SLC 5/04, and SLC 5/05, or PLC-5 processors configured for DF1 Half-Duplex Master.

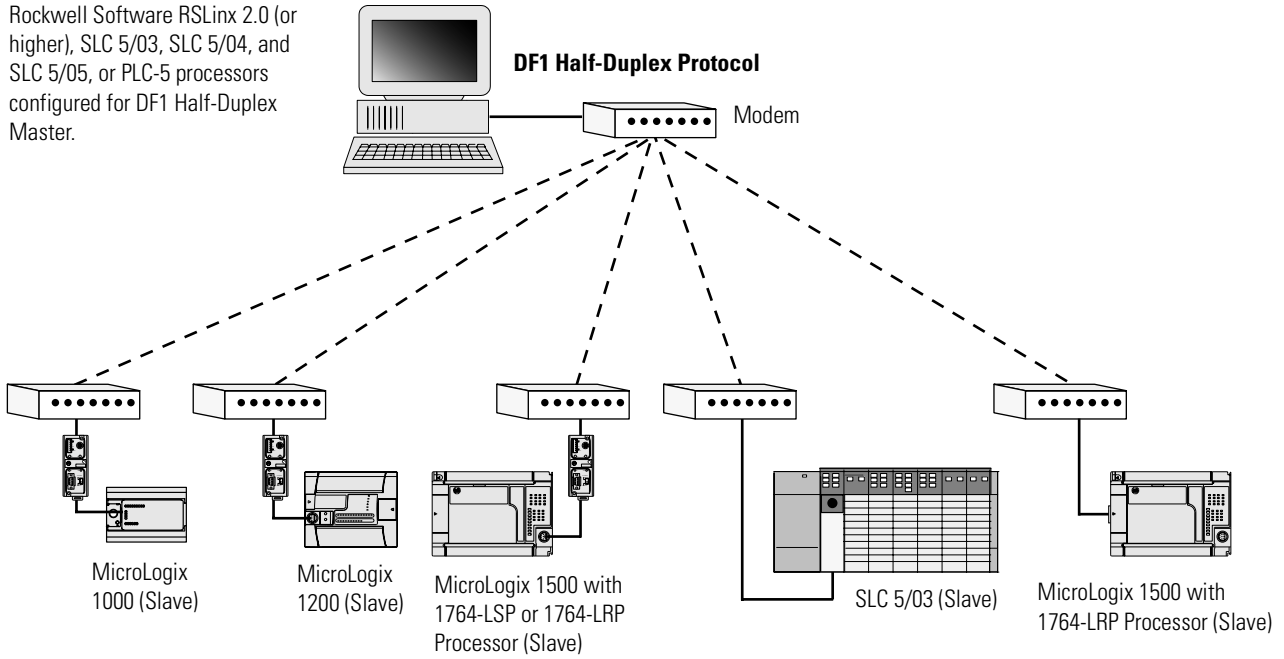

## Connecting to a DH-485 Network

The following network diagrams provide examples of how to connect MicroLogix 1500 controllers to the DH-485 network using the Advanced Interface Converter (AIC+, catalog number 1761-NET-AIC). For more information on the AIC+, see the *Advanced Interface Converter and DeviceNet Interface Installation Instructions*, Publication 1761-5.11.

*DH-485 Network with a MicroLogix 1500 Controller*

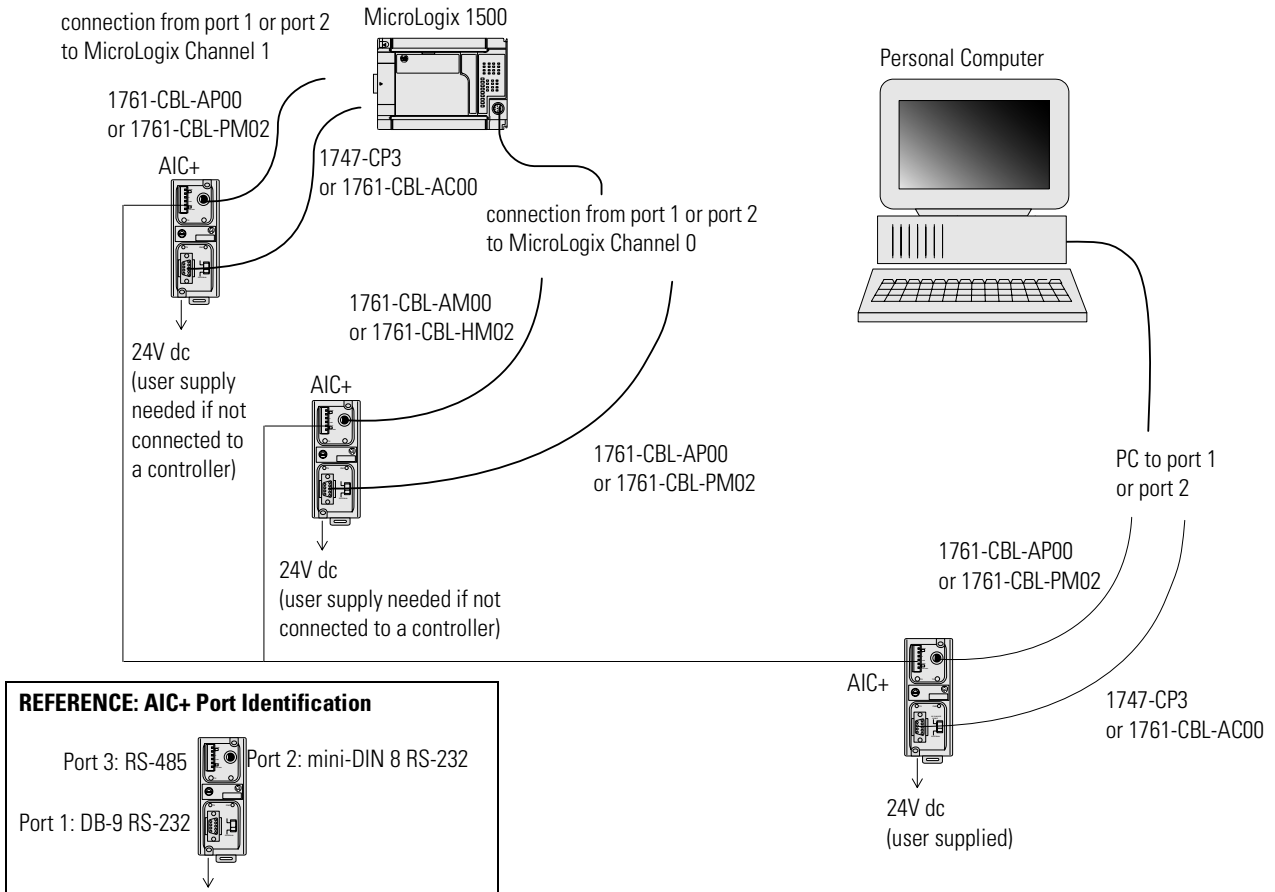

*Typical 3-Node Network (Channel 0 Connection)*

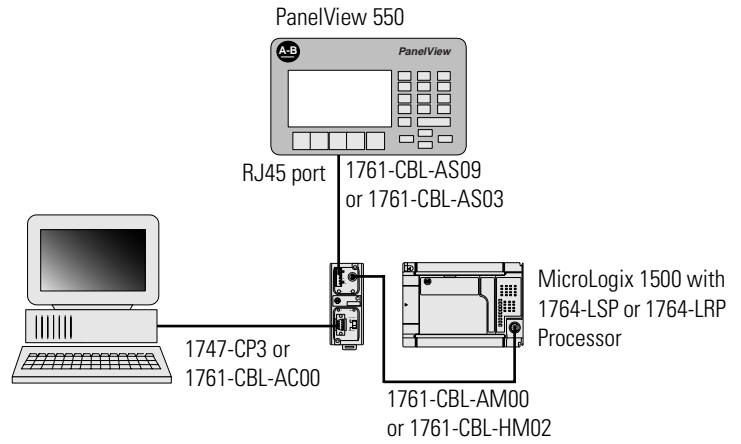

*Typical 3-Node Network (Channel 1 Connection)*

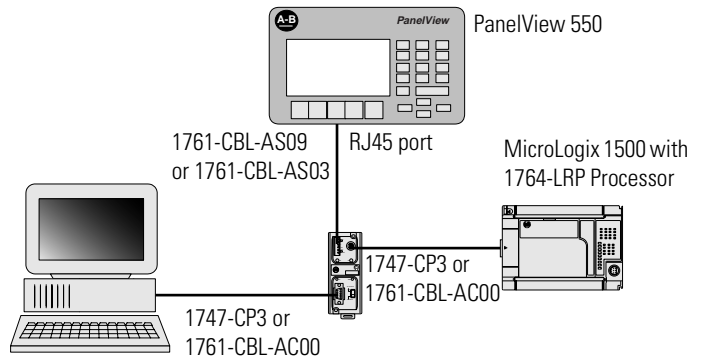

*Networked Operator Interface Device and MicroLogix Controllers*

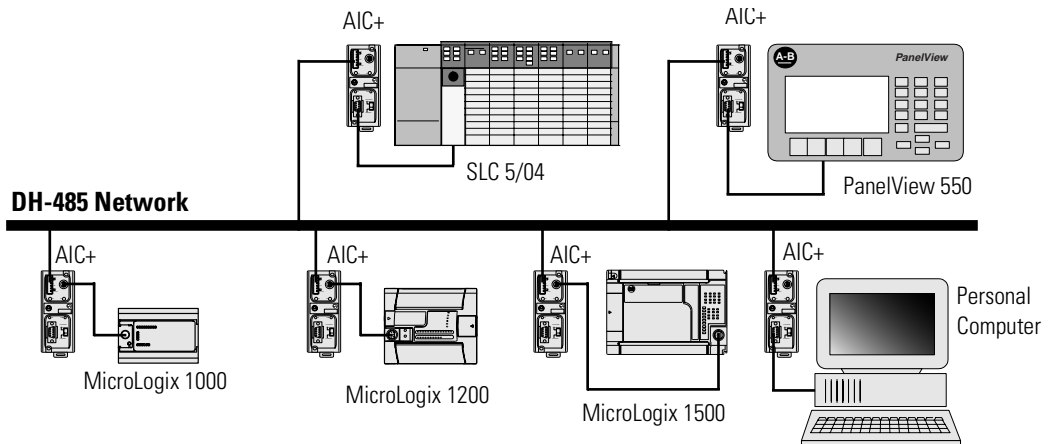

## DH-485 Configuration Parameters

When MicroLogix communications are configured for DH-485, the following parameters can be changed:

**Table 4.4 DF1 Full-Duplex Configuration Parameters**

Parameter	Options
Baud Rate	9600, 19.2K
Node Address	1 to 31 decimal
Token Hold Factor	1 to 4

See Software Considerations on page E-10 for tips on setting the parameters listed above.

## Recommended Tools

To connect a DH-485 network, you need tools to strip and attach the shielded cable. We recommend the following equipment (or equivalent):

**Table 4.5 Working with Cable for DH-485 Network**

Description	Part Number	Manufacturer
Shielded Twisted Pair Cable	#3106A or #9842	Belden
Stripping Tool	45-164	Ideal Industries
1/8" Slotted Screwdriver	Not Applicable	Not Applicable

## DH-485 Communication Cable

The communication cable consists of a number of cable segments daisy-chained together. The total length of the cable segments cannot exceed 1219 m (4000 ft). However, two segments can be used to extend the DH-485 network to 2438m (8000 ft). For additional information on connections using the AIC+, refer to the *Advanced Interface Converter (AIC+) User Manual*, publication 1761-6.4.



## Communication Cable Connection to the DH-485 Connector

**TIP** A daisy-chained network is recommended. We do *not* recommend the following:

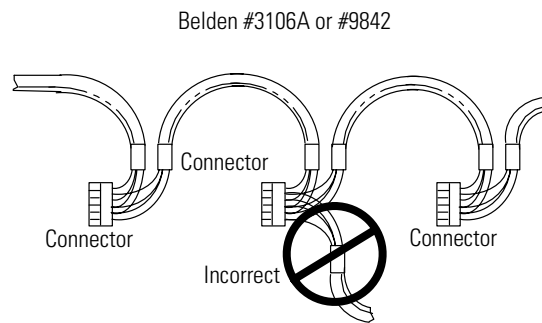

### Single Cable Connection

When connecting a single cable to the DH-485 connector, use the following diagram.

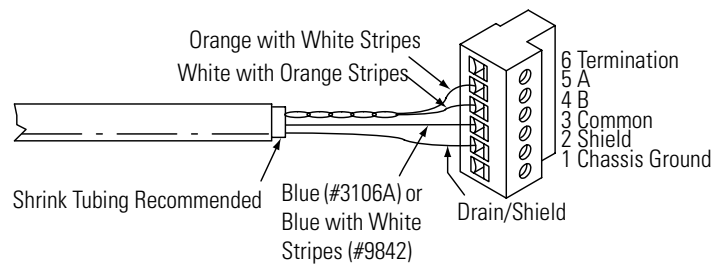

### Multiple Cable Connection

When connecting multiple cables to the DH-485 connector, use the following diagram.

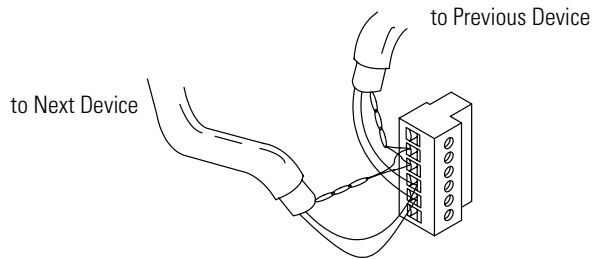

**Table 4.6 Connections using Belden #3106A Cable**

For this Wire/Pair	Connect this Wire	To this Terminal
Shield/Drain	Non-jacketed	Terminal 2 - Shield
Blue	Blue	Terminal 3 - (Common)
White/Orange	White with Orange Stripe	Terminal 4 - (Data B)
	Orange with White Stripe	Terminal 5 - (Data A)

**Table 4.7 Connections using Belden #9842 Cable**

For this Wire/Pair	Connect this Wire	To this Terminal
Shield/Drain	Non-jacketed	Terminal 2 - Shield
Blue/White	White with Blue Stripe	Cut back - no connection <sup>(1)</sup>
	Blue with White Stripe	Terminal 3 - (Common)
White/Orange	White with Orange Stripe	Terminal 4 - (Data B)
	Orange with White Stripe	Terminal 5 - (Data A)

(1) To prevent confusion when installing the communication cable, cut back the white with blue stripe wire immediately after the insulation jacket is removed. This wire is not used by DH-485.

### Grounding and Terminating the DH-485 Network

Only one connector at the end of the link must have Terminals 1 and 2 jumpered together. This provides an earth ground connection for the shield of the communication cable. Both ends of the network must have Terminals 5 and 6 jumpered together, as shown below. This connects the termination impedance (of 120Ω) that is built into each AIC+ as required by the DH-485 specification.

*End-of-Line Termination*

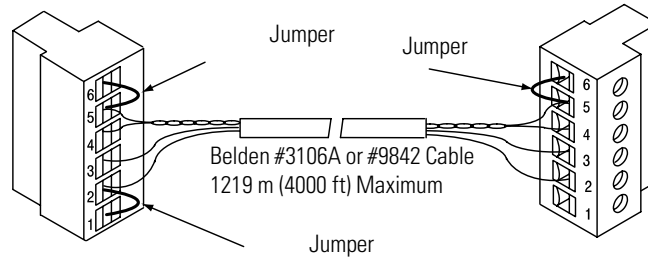

**Connecting the AIC+**

The AIC+, catalog number 1761-NET-AIC, enables MicroLogix controllers to connect to a DH-485 network when they are configured for DH-485 protocol. The AIC+ has two isolated RS-232 ports and one RS-485 port. When two MicroLogix controllers are closely positioned, you can connect a controller to each of the RS-232 ports on the AIC+.

The AIC+ can also be used as an RS-232 isolator, providing an isolation barrier between the controllers communications port and any equipment connected to it (i.e. personal computer, modem, etc.)

The following figure shows the connections and specifications of the AIC+.

Item	Description
1	Port 1 - DB-9 RS-232, DTE
2	Port 2 - mini-DIN 8 RS-232 DTE
3	Port 3 - RS-485 Phoenix plug
4	DC Power Source selector switch (cable = port 2 power source, external = external power source connected to item 5)
5	Terminals for external 24V dc power supply and chassis ground

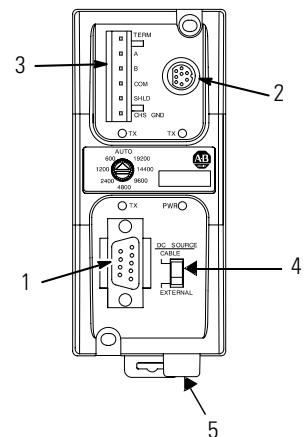

For additional information on connecting the AIC+, refer to the *Advanced Interface Converter (AIC+) User Manual*, publication 1761-6.4.

*Cable Selection Guide*



Cable	Length	Connections from	to AIC+	External Power Supply Required <sup>(1)</sup>	Power Selection Switch Setting <sup>(1)</sup>
1761-CBL-AP00 1761-CBL-PM02	45cm (17.7 in) 2m (6.5 ft)	1764-LRP processor, channel 1	port 2	yes	external
		SLC 5/03 or SLC 5/04 processors, channel 0	port 2	yes	external
		MicroLogix 1000 or 1500	port 1	yes	external
		PanelView 550 through NULL modem adapter	port 2	yes	external
		DTAM Plus / DTAM Micro	port 2	yes	external
		PC COM port	port 2	yes	external

(1) External power supply required unless the AIC+ is powered by the device connected to port 2, then the selection switch should be set to *cabl*e.



Cable	Length	Connections from	to AIC+	External Power Supply Required <sup>(1)</sup>	Power Selection Switch Setting <sup>(1)</sup>
1761-CBL-AM00 1761-CBL-HM02	45cm (17.7 in) 2m (6.5 ft)	MicroLogix 1000 or 1500	port 2	no	cabl
		to port 2 on another AIC+	port 2	yes	external

(1) External power supply required unless the AIC+ is powered by the device connected to port 2, then the selection switch should be set to *cabl*e.



Cable	Length	Connections from	to AIC+	External Power Supply Required <sup>(1)</sup>	Power Selection Switch Setting <sup>(1)</sup>
1747-CP3 1761-CBL-AC00	3m (9.8 ft) 45cm (17.7 in)	1764-LRP processor, channel 1	port 1	yes	external
		SLC 5/03 or SLC 5/04 processor, channel 0	port 1	yes	external
		PC COM port	port 1	yes	external
		PanelView 550 through NULL modem adapter	port 1	yes	external
		DTAM Plus / DTAM Micro™	port 1	yes	external
		Port 1 on another AIC+	port 1	yes	external

(1) External power supply required unless the AIC+ is powered by the device connected to port 2, then the selection switch should be set to *cabl*e.



Cable	Length	Connections from	to AIC+	External Power Supply Required <sup>(1)</sup>	Power Selection Switch Setting <sup>(1)</sup>
straight 9-25 pin	—	modem or other communication device	port 1	yes	external

(1) External power supply required unless the AIC+ is powered by the device connected to port 2, then the selection switch should be set to *cabl*e.



Cable	Length	Connections from	to AIC+	External Power Supply Required <sup>(1)</sup>	Power Selection Switch Setting <sup>(1)</sup>
1761-CBL-AS03 1761-CBL-AS09	3m (9.8 ft) 9.5m (31.17 ft)	SLC 500 Fixed, SLC 5/01, SLC 5/02, and SLC 5/03 processors	port 3	yes	external
		PanelView 550 RJ45 port	port 3	yes	external

(1) External power supply required unless the AIC+ is powered by the device connected to port 2, then the selection switch should be set to *cabl*e.

1761-CBL-PM02 (or equivalent) Cable Wiring Diagram

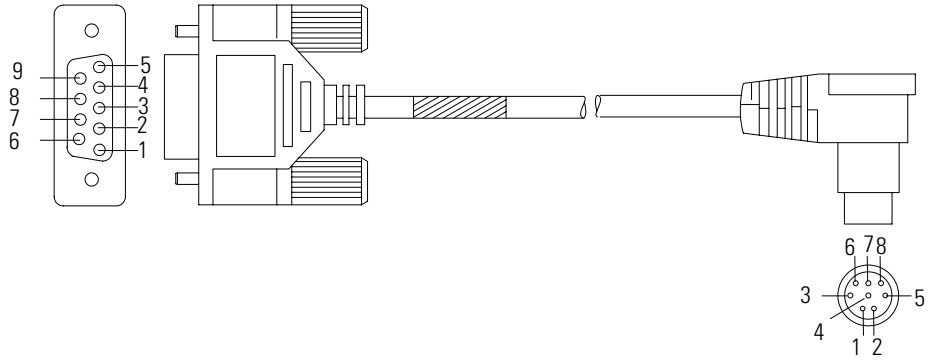

**Programming Device**

9-Pin D-Shell

9	RI
8	CTS
7	RTS
6	DSR
5	GND
4	DTR
3	TXD
2	RXD
1	DCD

**Controller**

8-Pin Mini Din

24V	1
GND	2
RTS	3
RXD	4
DCD	5
CTS	6
TXD	7
GND	8

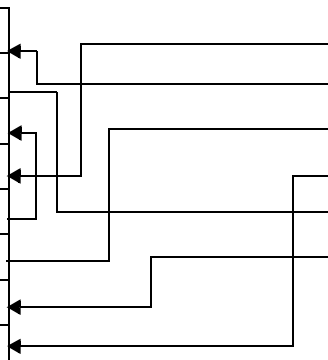

### Recommended User-Supplied Components

The components in Table 4.8 can be purchased from your local electronics supplier.

**Table 4.8 User Supplied Components**

Component	Recommended Model
external power supply and chassis ground	power supply rated for 20.4-28.8V dc
NULL modem adapter	standard AT
straight 9-25 pin RS-232 cable	see table below for port information if making own cables

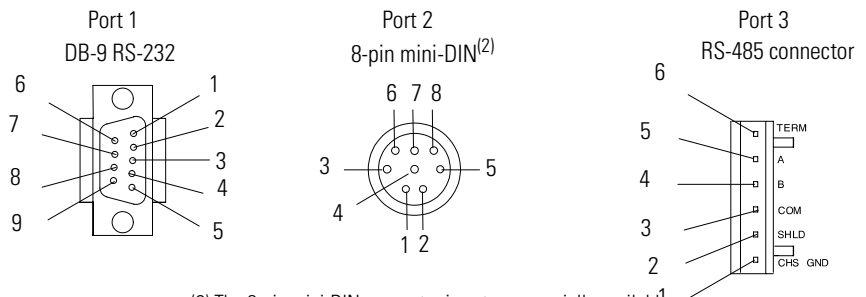

(2) The 8-pin mini-DIN connector is not commercially available.

**Table 4.9 AIC+ Terminals**

Pin	Port 1: DB-9 RS-232	Port 2 <sup>(2)</sup>	Port 3: RS-485 Connector
1	received line signal detector (DCD)	24V dc	chassis ground
2	received data (RxD)	ground (GND)	cable shield
3	transmitted data (TxD)	request to send (RTS)	signal ground
4	DTE ready (DTR) <sup>(1)</sup>	received data (RxD)	DH-485 data B
5	signal common (GND)	received line signal detector (DCD)	DH-485 data A
6	DCE ready (DSR) <sup>(2)</sup>	clear to send (CTS)	termination
7	request to send (RTS)	transmitted data (TxD)	not applicable
8	clear to send (CTS)	ground (GND)	not applicable
9	not applicable	not applicable	not applicable

(1) On port 1, pin 4 is electronically jumpered to pin 6. Whenever the AIC+ is powered on, pin 4 will match the state of pin 6.

(2) An 8-pin mini DIN connector is used for making connections to port 2. This connector is not commercially available.

### *Safety Considerations*

This equipment is suitable for use in Class I, Division 2, Groups A, B, C, D or non-hazardous locations only.

---

**WARNING****EXPLOSION HAZARD**

This product must be installed in an enclosure. All cables connected to the product must remain in the enclosure or be protected by conduit or other means.

---

See Safety Considerations on page 2-3 for additional information.

### *Installing and Attaching the AIC+*

1. Take care when installing the AIC+ in an enclosure so that the cable connecting the MicroLogix 1500 controller to the AIC+ does not interfere with the enclosure door.
2. Carefully plug the terminal block into the RS-485 port on the AIC+ you are putting on the network. Allow enough cable slack to prevent stress on the plug.
3. Provide strain relief for the Belden cable after it is wired to the terminal block. This guards against breakage of the Belden cable wires.

### *Powering the AIC+*

In normal operation with a MicroLogix programmable controller connected to port 2 of the AIC+, the controller powers the AIC+. Any AIC+ not connected to a MicroLogix controller requires a 24V dc power source. The AIC+ requires 120 mA at 24V dc.

If both the controller and external power are connected to the AIC+, the power selection switch determines what device powers the AIC+.

---

**ATTENTION**

If you use an external power supply, it must be 24V dc. Permanent damage results if higher voltage is used.

---



Set the DC Power Source selector switch to EXTERNAL before connecting the power supply to the AIC+. The following illustration shows where to connect external power for the AIC+.

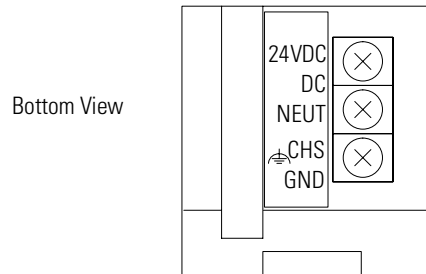

---

**ATTENTION**

Always connect the CHS GND (chassis ground) terminal to the nearest earth ground. This connection must be made whether or not an external 24V dc supply is used.

---

### *Power Options*

Below are two options for powering the AIC+:

- Use the 24V dc user power supply built into the MicroLogix 1500 controller. The AIC+ is powered through a hard-wired connection using a communication cable (1761-CBL-HM02, or equivalent) connected to port 2.
- Use an external DC power supply with the following specifications:
  - operating voltage: 24V dc +20% or -15%
  - output current: 150 mA minimum
  - rated NEC Class 2

Make a hard-wired connection from the external supply to the screw terminals on the bottom of the AIC+.

---

**ATTENTION**

If you use an external power supply, it must be 24V dc. Permanent damage results if miswired with the wrong power source.

---

## Connecting to DeviceNet

You can connect a MicroLogix 1500 using DF1 Full-Duplex protocol to a DeviceNet network using the DeviceNet Interface (DNI), catalog number 1761-NET-DNI. For additional information on using the DNI, refer to the *DeviceNet Interface User Manual*, publication 1761-6.5. The following figure shows the external wiring connections of the DNI.

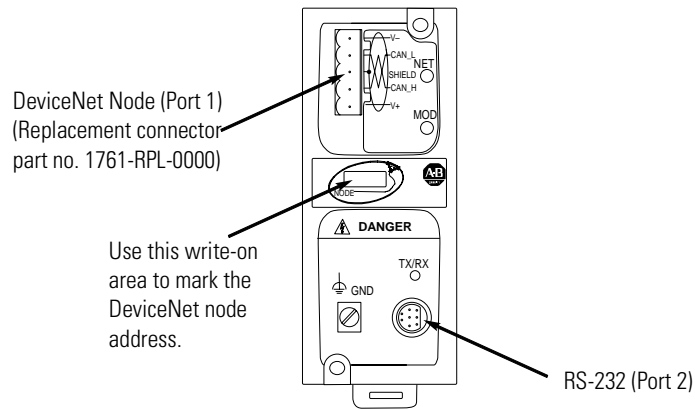

## Cable Selection Guide



Cable	Length	Connections from	to DNI
1761-CBL-AM00	45 cm (17.7 in)	MicroLogix 1000	port 2
1761-CBL-HM02	2m (6.5 ft)	MicroLogix 1500	port 2



Cable	Length	Connections from	to DNI
1761-CBL-AP00	45 cm (17.7 in)	SLC 5/03 or SLC 5/04 processors, channel 0	port 2
1761-CBL-PM02	2m (6.5 ft)	PC COM port	port 2
		1764-LRP processor, channel 1	port 2

## Connecting to Ethernet

You can connect a MicroLogix 1500 to an Ethernet network using the Ethernet Interface (ENI), catalog number 1761-NET-ENI. For additional information on using the ENI, refer to the *Ethernet Interface User Manual*, publication 1761-UM006. The following figure shows the external wiring connections of the ENI.

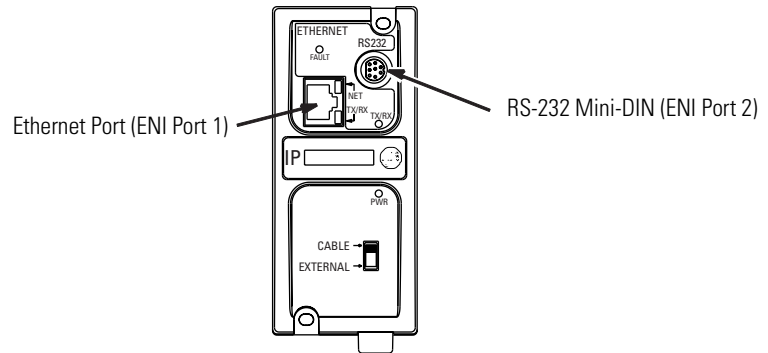

## Ethernet Connections

The Ethernet connector, port 1, is an RJ45, 10Base-T connector. The pin-out for the connector is shown below:

Pin	Pin Name
1	Tx+
2	Tx-
3	Rx+
4	not used by 10Base-T
5	not used by 10Base-T
6	Rx-
7	not used by 10Base-T
8	not used by 10Base-T

When to use straight-through and cross-over cable:

- ENI Ethernet port to 10Base-T Ethernet switch cables utilize a straight-through pin-out (1-1, 2-2, 3-3, 6-6).
- Direct point-to-point 10Base-T cables connecting the ENI Ethernet port directly to another ENI Ethernet port (or a computer 10Base-T port) require a cross-over pin-out (1-3, 2-6, 3-1, 6-2).

### RS-232 Connections

Port 2 of the ENI is an 8-pin mini-DIN RS-232 port that provides connection to DF1 compatible RS-232 devices. The connector pin assignments are shown below.

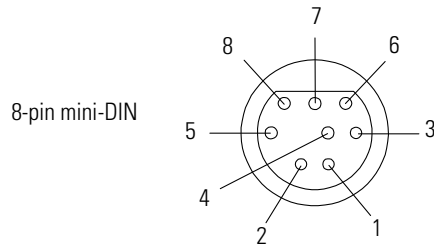

Pin	Port 2
1	24V dc
2	ground (GND)
3	no connection
4	ENI input data, RxD
5	no connection
6	no connection
7	ENI output data, TxD
8	ground (GND)

The table below describes the RS-232 compatible cables.

ENI Connected to:	Catalog Number	Use Cable
MicroLogix (all series)	1761-CBL-AM00 1761-CBL-HM02	Mini DIN to Mini DIN 45 cm (17.7 in) 2m (6.5 ft.)
SLC 5/03, SLC 5/04, or SLC 5/05 Channel 0	1761-CBL-AP00 1761-CBL-PM02	Mini DIN to D-Shell 45 cm (17.7 in) 2m (6.5 ft.)
PLC-5	1761-CBL-AP00 1761-CBL-PM02	Mini DIN to D-Shell 45 cm (17.7 in) 2m (6.5 ft.)

## Using Trim Pots and the Data Access Tool (DAT)

### Trim Pot Operation

The processor has two trimming potentiometers (trim pots) which allow modification of data within the controller. Adjustments to the trim pots change the value in the corresponding Trim Pot Information (TPI) register. The data value of each trim pot can be used throughout the control program as timer, counter, or analog presets depending upon the requirements of the application.

The trim pots are located below the mode switch under the left access door of the processor.

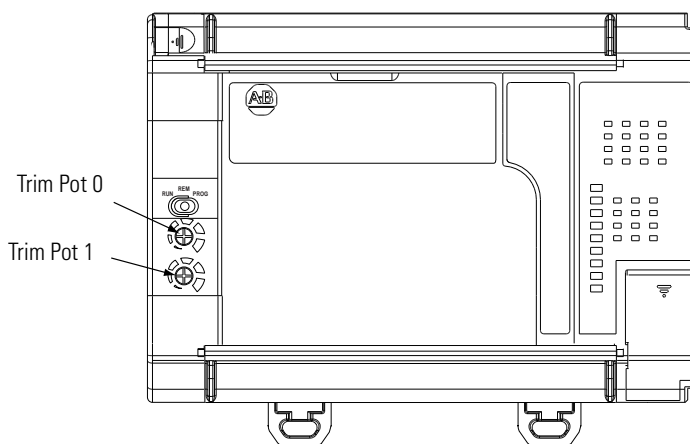

Use a small flathead screwdriver to turn the trim pots. Adjusting their value causes data to change within a range of 0 to 250 (fully clockwise). The maximum rotation of each trim pot is three-quarters, as shown below. Trim pot stability over time and temperature is typically  $\pm 2$  counts.

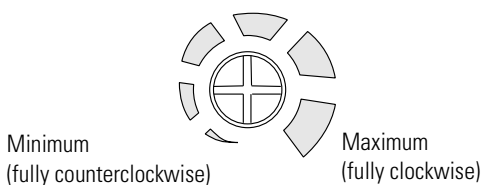

Trim pot data is updated continuously whenever the controller is powered-up.

## Trim Pot Information Function File

The composition of the Trim Pot Information (TPI) Function File is described in the *MicroLogix 1200 and MicroLogix 1500 Instruction Set Reference Manual*, publication 1762-RM001.

## Error Conditions

If the controller detects a problem/error with either trim pot, the last values read remain in the data location, and an error code is put in the error code byte of the TPI file for whichever trim pot had the problem. Once the problem/error is corrected, the error code is cleared. The error codes are described in the *MicroLogix 1200 and MicroLogix 1500 Instruction Set Reference Manual*, publication 1762-RM001.

## Data Access Tool (DAT)

The DAT is a convenient and simple tool that provides an interface for editing and monitoring data. The DAT has five primary features:

- provides direct access to 48 bit elements
- provides direct access to 48 integer elements
- provides two function keys
- displays controller faults
- allows removal/insertion under power

## DAT Keypad and Indicator Light Functions

The DAT has a digital display, 6 keys, an up/down key, and 7 indicator lights. Their functions are described in the table on page 5-3.

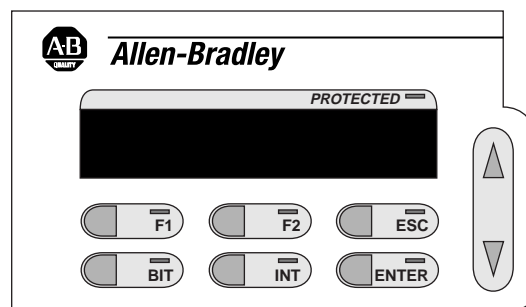

Feature	Function
Digital Display	Displays address elements, data values, faults and errors.
Up/Down Key	Selects element numbers and change data values. The up/down key scrolls when held.
F1 Key and Indicator Light	Controls the F1 status bit. When the F1 key is pressed or latched, the F1 indicator LED is lit.
F2 Key and Indicator Light	Controls the F2 status bit. When the F2 key is pressed or latched, the F2 indicator LED is lit.
ESC Key	Cancels a current operation.
BIT Key and Indicator Light	Pressing the BIT key puts the DAT in bit mode. The bit indicator light is on when the DAT is in bit mode.
INT Key and Indicator Light	Pressing the INT key puts the DAT in integer mode. The integer indicator light is on when the DAT is in integer mode.
ENTER Key	Press to select the flashing element number or enter data value.
PROTECTED Indicator Light	Indicates element data cannot be changed using the DAT (element is read-only).

**TIP**

The F1, F2, ESC, BIT, INT, and ENTER keys do not repeat when held. Holding down any one of these keys results in only one key press. The Up/Down arrow key is the only key that repeats when held.

## Power-Up Operation

The DAT receives power when it is plugged into the controller. Upon power-up, the DAT performs a self-test.

If the test fails, the DAT displays an error code, all indicator lights are deactivated, and the DAT does not respond to any key presses. See DAT Error Codes on page 5-10.

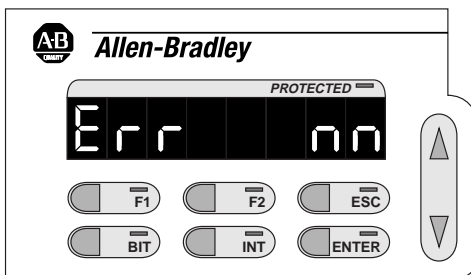

After a successful self-test, the DAT reads the DAT function file to determine its configuration.

## DAT Function File

DAT configuration is stored in the processor in a specialized configuration file called the DAT Function File. The DAT Function File, which is part of the user's control program, is described in the *MicroLogix 1200 and MicroLogix 1500 Instruction Set Reference Manual*, publication 1762-RM001.

Following a successful power-up sequence, the DAT enters the bit monitoring mode.

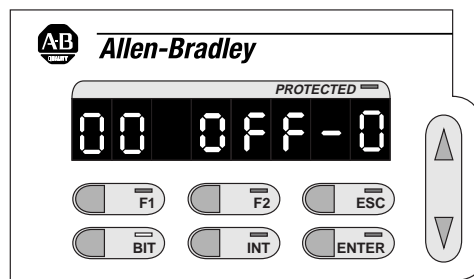

## Power Save Timeout (PST) Parameter

The power save timeout turns off the DAT display after keypad activity has stopped for a user-defined period of time. The power-save (DAT:0.PST) value is set in the DAT Function File. The valid range is 0 to 255 minutes. The power-save feature can be disabled by setting the PST value to 0, which keeps the display on continuously. The default value is 0.

In power-save mode, a dash flashes in the left-most segment of the display. Press any key (except F1 or F2) to return the DAT to its previous mode. If F1 or F2 is pressed, the DAT will change the value of the F1 or F2 status bits, but the display remains in power-save mode.



## Understanding the DAT Display

When the DAT enters either the bit or integer mode, the element number and its data are displayed, as shown below. The element number is either the integer or bit location.

**Bit Mode Display**

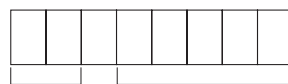
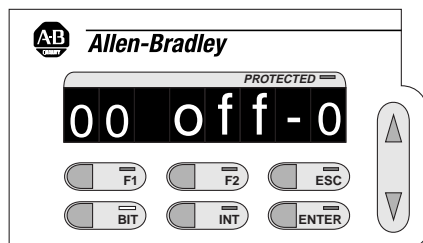

bit element  
number

- 0 to 47

bit data

- OFF - 0
- ON - 1
- --- (undefined)

**Integer Mode Display**

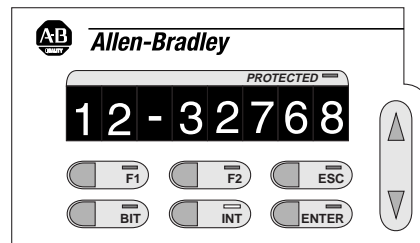

integer  
element  
number

- 0 to 47

integer data

- -32,768 to 32,767
- --- (undefined)

If the displayed element is defined in the controller's data file, and is not protected, the element number flashes, indicating that it can be modified. If the displayed element is protected, the PROTECTED indicator light illuminates, and the element number does not flash, indicating that the element cannot be modified.

If the element is undefined, the data field displays three dashes. The element number does not flash because the element does not exist.

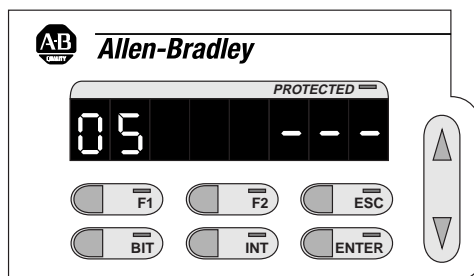

## Entering Bit Mode

Bit mode allows you to view and modify up to 48 contiguous bit locations in the controller. The DAT enters the bit mode automatically following a successful power-up. The bit mode can also be selected by pressing the BIT key. If the bit mode was previously active, the DAT displays the last bit element monitored. If the integer mode was active, the DAT displays the first bit element in the data file. However, there may be a brief delay while the DAT requests information from the controller. During the delay, the working screen will display. See Working Screen Operation on page 5-7.

## Entering Integer Mode

Integer mode allows you to view and modify up to 48 contiguous 16-bit integer data locations in the controller. To initiate integer mode, press the INT key. If the integer mode was previously active, the DAT displays the last integer element monitored. If the bit mode was active, the DAT displays the first integer element in the data file. However, there may be a brief delay while the DAT requests information from the controller. If there is a delay, the working screen is displayed. See Working Screen Operation on page 5-7.

## Monitoring and Editing

1. Press the INT or BIT key to enter the desired mode. The element number flashes (if not protected).
2. Use the up/down key to scroll and select an element (to scroll rapidly, hold the up/down key).
3. Press ENTER to edit the element. The element number becomes steady and the data flashes if it is not protected.
4. Use the up/down key to change the data. Bit values toggle between “ON” and “OFF”. Integer values increment or decrement. Holding down the up/down key causes the integer value to increment or decrement quickly.

**TIP**

If the data is protected or undefined, pressing the up/down key scrolls to the next element in the list.



5. Press ENTER to load the new data. Press ESC or INT/BIT to discard the new data.

## F1 and F2 Functions

The function keys, F1 and F2, correspond to bits and can be used throughout the control program as desired. They have no effect on bit or integer monitoring.

Each key has two corresponding bits in the DAT function file. The bits within the DAT function file are shown in the table below.

Key	Bits	Address	Data Format	Type	User Program Access
F1 Key	Pressed	DAT:0/F1P	Binary	Status	Read/Write
	Latched	DAT:0/F1L	Binary	Status	Read/Write
F2 Key	Pressed	DAT:0/F2P	Binary	Status	Read/Write
	Latched	DAT:0/F2L	Binary	Status	Read/Write

### *F1 or F2 Key Pressed*

The pressed bits (DAT:0/F1P and DAT:0/F2P) function as push-buttons and provide the current state of either the F1 or F2 key on the keypad. When the F1 or F2 key is pressed, the DAT sets (1) the corresponding pressed key bit. When the F1 or F2 key is not pressed, the DAT clears (0) the corresponding pressed key bit.

### *F1 or F2 Key Latched*

The latched bits (DAT:0/F1L and DAT:0/F2L) function as latched push-buttons and provide latched/toggle key functionality. When the F1 or F2 key is pressed, the DAT sets (1) the corresponding latched key bit within the DAT Function File. When the F1 or F2 key is pressed a second time, the DAT clears (0) the corresponding latched key bit.

## Working Screen Operation

Because the DAT is a communications device, its performance is affected by the scan time of the controller. Depending on the user program, if a long scan time is encountered and the DAT waits for information from the controller, a working screen is displayed. The

working screen consists of three dashes that move across the display from left to right. While the working screen is displayed, key presses are not recognized. Once the DAT receives data from the controller, it returns to its normal mode of operation.

If you encounter excessive working screen conditions, you can minimize the effect by adding an SVC instruction to the control program. Refer to the *MicroLogix 1200 and MicroLogix 1500 Programmable Controllers Instruction Set Reference Manual*, publication 1762-RM001, for information on the SVC instruction.

## Non-Existent Elements

When the DAT determines that an element number does not exist in the controller, the element value displays as three dashes.

If the protection bit for an element is undefined, the DAT will assume that the element is unprotected.

## Controller Faults

The DAT checks for controller faults every 10 seconds. When the DAT detects a controller fault, the display shows “FL” in the element number field and the value of the controller’s major fault word (S2:6) is displayed in the value field, as shown below.

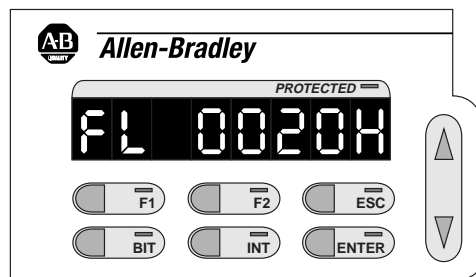

### TIP



If an element value is being modified when the fault is detected, the fault is stored until the modification is accepted or discarded. Then, the fault will be displayed.

Pressing ESC while the fault is being displayed returns the DAT to its previous mode. The fault is not removed from the controller, just from the DAT display screen. The fault that was on screen will not display again and cannot be “recalled”. If a new fault is detected, it will be displayed. If the initial fault is cleared and returns at a later time, the DAT will display the fault at that time.

## Error Conditions

When the DAT detects an error in its own operation, it displays the error screen. The error screen consists of “Err” and a two-digit error code, as shown below.

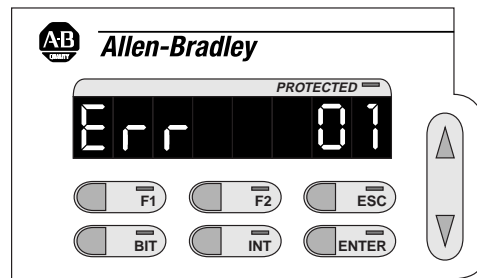

The DAT can experience two different types of errors, internal errors and communication errors.

### *Internal DAT Errors*

Internal DAT errors are non-recoverable. When the DAT experiences an internal error, it displays the error screen, and does not respond to any key presses. Remove and re-install the DAT. If this does not clear the error, the DAT must be replaced.

### *Communication Errors*

The DAT continually monitors the interface between the DAT and the controller to ensure a good communication path. If the DAT loses communication with the controller for more than three seconds, it generates an interface time-out error. The DAT automatically attempts to re-establish communications. The error screen displays until the DAT regains communications with the processor. All key presses are ignored until the display clears.

*DAT Error Codes*

<b>Error Code</b>	<b>Description</b>	<b>Caused by</b>	<b>Recommended Action</b>
00	Interface time-out	Communication traffic	Add SVC instructions to ladder program
01 to 02	Power-up test failure	Internal failure	Remove and re-insert the DAT. If failure persists, replace the unit.
03 to 07	internal error	Internal failure	Remove and re-insert the DAT. If failure persists, replace the unit.
08	processor owned <sup>(1)</sup>	Another device has ownership of the controller	Release ownership by the other device
09	access denied	Cannot access that file because another device has ownership	Release file ownership by the other device
31 to 34	internal error	Internal failure	Remove and re-insert the DAT. If failure persists, replace the unit.

(1) This error can occur after a download in which communications configurations are changed. This error can be cleared by removing and re-installing the DAT, or by cycling power to the controller.

## Using Real-Time Clock and Memory Modules

Five modules with different levels of functionality are available for use with the MicroLogix 1500 controller.

Catalog Number	Function	Memory Size
1764-RTC	Real-Time Clock	not applicable
1764-MM1	Memory Module	8K
1764-MM1RTC	Memory Module and Real-Time Clock	8K
1764-MM2 <sup>(1)</sup>	Memory Module	16K
1764-MM2RTC <sup>(1)</sup>	Memory Module and Real-Time Clock	16K

(1) For 1764-LRP programs greater than 8k, use the 1764-MM2 or 1764-MM2RTC.

### Real-Time Clock Operation Removal/Insertion Under Power

The real-time clock module can be installed or removed at any time without risk of damage to either the module or the controller. If a module is installed while the MicroLogix 1500 is in an executing mode (Run or Remote Run), the module is not recognized until either a power cycle occurs, or until the controller is placed in a non-executing mode (program mode or fault condition).

Removal of the memory module is detected within one program scan. Removal of the real-time clock under power causes the controller to write zeros to the (RTC) Function File.

### Real-Time Clock Function File

The real-time clock provides year, month, day of month, day of week, hour, minute, and second information to the Real-Time Clock (RTC) Function File in the controller. Refer to the *MicroLogix 1200 and MicroLogix 1500 Instruction Set Reference Manual*, publication 1762-RM001 for information about the RTC function file.

## Accuracy

The following table indicates the expected accuracy of the real-time clock at various temperatures.

Ambient Temperature	Accuracy <sup>(1)</sup>
0°C (+32°F)	+34 to -70 seconds/month
+25°C (+77°F)	+36 to -68 seconds/month
+40°C (+104°F)	+29 to -75 seconds/month
+55°C (+131°F)	-133 to -237 seconds/month

(1) These numbers are expected worst case values over a 31 day month.

## Writing Data to the Real-Time Clock

When valid data is sent to the real-time clock from the programming device, the new values take effect immediately.

The real-time clock does not allow you to write invalid date or time data.

## RTC Battery Operation

The real-time clock has an internal battery that is not replaceable. The RTC Function File features a battery low indicator bit (RTC:0/BL), which shows the status of the RTC battery. When the battery is low, the indicator bit is set (1). This means that the battery may fail within 14 days and the real-time clock module needs to be replaced. When the battery low indicator bit is clear (0), the battery level is acceptable or a real-time clock is not attached.

If the RTC battery is low and the controller is powered, the RTC operates normally. If the controller power is removed and the RTC battery is low, RTC data may be lost.



Use the *Disable Clock* button in your programming device to disable the real-time clock before storing a module. This decreases the drain on the battery during storage.

**Table 6.1 RTC Battery Life Expectancy**

Battery State	Temperature	Time Duration
Operating	0°C to +40°C (+32°F to +104°F)	5 years <sup>(1)</sup>
Storage	-40°C to +25°C (-40°F to +77°F)	5 years minimum
	+26°C to +60°C (+79°F to +140°F)	3 years minimum

(1) The operating life of the battery is based on 6 months of storage time before the real-time clock is used.

### ATTENTION



Operating with a low battery indication for more than 14 days may result in invalid RTC data if controller power is lost.

## Memory Module Operation

The memory module supports program back-up as well as the following features:

- User Program and Data Back-Up
- Program Compare
- Data File Download Protection
- Memory Module Write Protection
- Removal/Insertion Under Power

### User Program and Data Back-Up

The memory module provides a simple and flexible program/data transport mechanism, allowing the user to transfer the program and data to the controller without the use of a personal computer and programming software.

The memory module can store one user program at a time.

During transfers from a memory module, the controller's RUN LED flashes.

## Program Compare

The memory module can also provide application security, allowing you to specify that if the program stored in the memory module does not match the program in the controller, the controller will not enter an executing (run or remote run) mode. To enable this feature, set the S:2/9 bit in the system status file. Refer to the *MicroLogix 1200 and MicroLogix 1500 Instruction Set Reference Manual*, publication 1762-RM001, for more information.

## Data File Download Protection

The memory module allows the user to specify individual data files in the controller that are protected from the download procedure. This allows user data to be saved (not overwritten) during a download.

**TIP**

Data file download protection is only functional if the processor does not have a fault and if all protected data files in the memory module exactly match the protected data file structure within the controller. Refer to the *MicroLogix 1200 and MicroLogix 1500 Instruction Set Reference Manual*, publication 1762-RM001, for information on protecting data files during download.

## Memory Module Write Protection

The memory module supports write-once, read-many behavior. Write protection is enabled using your programming software.

---

**IMPORTANT**

Once set, write protection cannot be removed. A change cannot be made to the control program or data stored in a write-protected memory module. If a change is required, you must use a different memory module.

---

## Removal/Insertion Under Power

The memory module can be installed or removed at any time without risk of damage to either the memory module or the controller. If a memory module is installed while the MicroLogix 1500 is executing, the memory module will not be recognized until either a power cycle occurs, or until the controller is placed in a non-executing mode (program mode or fault condition).

## Memory Module Information File

The controller has a Memory Module Information (MMI) File which provides status from the attached memory module. At power-up or on detection of a memory module being inserted, the catalog number, series, revision, and type (memory module and/or real-time clock) are identified and written to the MMI file. If a memory module and/or real-time clock is not attached, zeros are written to the MMI file. Refer to the *MicroLogix 1200 and MicroLogix 1500 Instruction Set Reference Manual*, publication 1762-RM001, for more information. ■



## Specifications

### Controller Specifications

**Table A.1 General Specifications**

Description	1764-24BWA	1764-24AWA	1764-28BxB
Number of I/O	12 inputs 12 outputs	12 inputs 12 outputs	16 inputs 12 outputs
Line Power	85 to 265V ac at 47 to 63 Hz	85 to 265V ac at 47 to 63 Hz	20.4 to 30V dc
Power Supply Usage	88 VA	70 VA	30W <sup>(2)</sup>
Power Supply Inrush	120V ac = 25A for 8 ms 240V ac = 40A for 4 ms	120V ac = 25A for 8 ms 240V ac = 40A for 4 ms	24V dc = 4A for 150 ms
User Power Output	24V dc at 400 mA, 400 µF max.	none	none
Input Circuit Type	24V dc, sink/source	120V ac	24V dc, sink/source
Output Circuit Type	relay	relay	6 relay, 6 FET transistor (24V dc source)
Typical CPU Hold-up Time	10 to 3000 ms		
Operating Temp.	+0°C to +55°C (+32°F to +131°F) ambient		
Storage Temp.	-40°C to +85°C (-40°F to +185°F) ambient <sup>(1)</sup>		
Operating Humidity	5% to 95% relative humidity (non-condensing)		
Vibration	Operating: 10 to 500 Hz, 5G, 0.030 in. max. peak-to-peak Relay Operation: 2G		
Shock (without Data Access Tool installed)	Operating: 30G panel mounted (15G DIN Rail mounted) Relay operation: 7.5G panel mounted (5G DIN Rail mounted) Non-Operating: 40G panel mounted (30G DIN Rail mounted)		
Shock (with Data Access Tool installed)	Operating: 20G panel mounted (15G DIN Rail mounted) Relay operation: 7.5G panel mounted (5G DIN Rail mounted) Non-Operating: 30G panel mounted (20G DIN Rail mounted)		
Agency Certification	<ul style="list-style-type: none"> <li>• UL 508</li> <li>• C-UL under CSA C22.2 no. 142</li> <li>• Class I, Div. 2, Groups A, B, C, D (UL 1604, C-UL under CSA C22.2 no. 213)</li> <li>• CE compliant for all applicable directives</li> <li>• C-Tick marked for all applicable acts</li> </ul>		

**Table A.1 General Specifications**

Description	1764-24BWA	1764-24AWA	1764-28BxB
Electrical/EMC	The module has passed testing at the following levels: <ul style="list-style-type: none"> <li>• EN61000-4-2: 4 kV contact, 8 kV air, 4 kV indirect</li> <li>• EN61000-4-3: 10 V/m</li> <li>• EN61000-4-4: 2 kV, 5 kHz; communications cable: 1 kV, 5 kHz</li> <li>• EN61000-4-5: communications cable 1 kv galvanic gun -I/O: 2 kV CM, 1 kV DM, -Power Supply (1764-24AWA/1764-24BWA): 4 kV CM, 2 kV DM -Power Supply (1764-28BxB): 0.5 kV CM, 0.5 kV DM</li> <li>• EN61000-4-6: 10V, communications cable 3V</li> </ul>		
Terminal Screw Torque	1.13 Nm (10 in-lb) rated; 1.3 Nm (12 in-lb) maximum		
Programming Software	For 1764-LSP Series A Processors: RSLogix 500, Version 3.01.09 or higher For 1764-LSP and 1764-LRP Series B Processors: RSLogix 500, Version 4.00.00 or higher.		

(1) Recommended storage temperature for maximum battery life (5 years typical with normal operating/storage conditions) of the 1764-RTC, 1764-MM1RTC, and 1764-MM2RTC is -40°C to +40°C (-40°F to +104°F). Battery life is significantly shorter at elevated temperatures.

(2) See Choosing a Power Supply on page A-2.

## Choosing a Power Supply

This section contains information for selecting a power supply for applications using a 1764-28BxB base unit. Use the tables in Appendix F to calculate the total power (Watts) consumed by the system. With that information, use the graphs below to chose a power supply. You can use either current or power, depending on how the power supply is rated.

**Figure 1.1 Input Current Required**

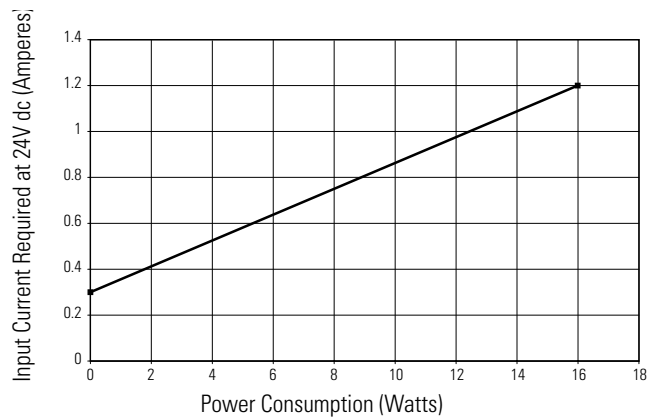

**Figure 1.2 Input Power Required**

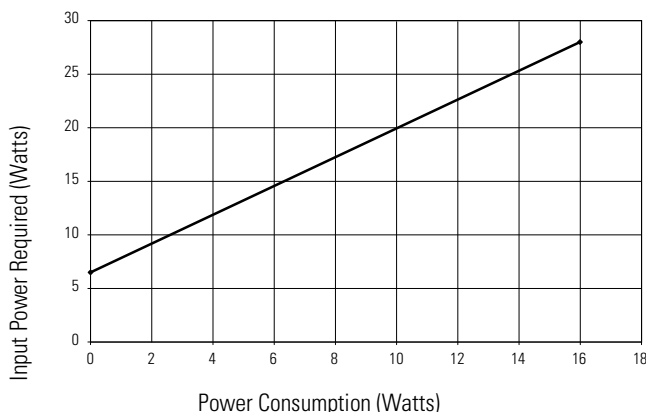

**Table A.2 Input Specifications**

Description	1764-24AWA	1764-24BWA and 1764-28BxB	
		Inputs 0 thru 7	Inputs 8 and Higher
On-State Voltage Range	79 to 132V ac	14 to 30.0V dc at 30°C (86°F) 14 to 26.4V dc at 55°C (131°F)	10 to 30.0V dc at 30°C (86°F) 10 to 26.4V dc at 55°C (131°F)
Off-State Voltage Range	0 to 20V ac	0 to 5V dc	
Operating Frequency	Not Applicable	1 kHz to 20 kHz	1 kHz to 500 Hz <sup>(1)</sup>
On-State Current: • minimum • nominal • maximum	• 5.0 mA at 79V ac • 12.0 mA at 120V ac • 16.0 mA at 132V ac	• 2.5 mA at 14V dc • 7.3 mA at 24V dc • 12.0 mA at 30V dc	• 2.0 mA at 10V dc • 8.9 mA at 24V dc • 12.0 mA at 30V dc
Off-State Leakage Current	2.5 mA minimum	1.5 mA minimum	
Nominal Impedance	12k ohms at 50 Hz 10k ohms at 60 Hz	3.3k ohms	2.7k ohms
Inrush Current (max.)	250 mA at 120V ac	Not Applicable	Not Applicable

(1) Scan-time dependant.



The 1764-24AWA input circuits (inputs 0-11) do not support adjustable filter settings. They have maximum turn-on and maximum turn-off times of 20 milliseconds.

**Table A.3 Response Times for High-Speed dc Inputs 0 Through 7  
(applies to 1764-24BWA and 1764-28BXB)**

<b>Maximum High-Speed Counter Frequency at 50% Duty Cycle (KHz)</b>	<b>Filter Setting (ms)</b>	<b>Minimum ON Delay (ms)</b>	<b>Maximum ON Delay (ms)</b>	<b>Minimum OFF Delay (ms)</b>	<b>Maximum OFF Delay (ms)</b>
20.000	0.025	0.005	0.025	0.005	0.025
6.700	0.075	0.040	0.075	0.045	0.075
5.000	0.100	0.050	0.100	0.060	0.100
2.000	0.250	0.170	0.250	0.210	0.250
1.000	0.500	0.370	0.500	0.330	0.500
0.500	1.000	0.700	1.000	0.800	1.000
0.250	2.000	1.700	2.000	1.600	2.000
0.125	4.000	3.400	4.000	3.600	4.000
0.063	8.000 <sup>(1)</sup>	6.700	8.000	7.300	8.000
0.031	16.000	14.000	16.000	14.000	16.000

(1) This is the default setting.

**Table A.4 Response Times for Normal dc Inputs 8 Through 11 (1764-24BWA)  
and 8 Through 15 (1764-28BXB)**

<b>Maximum Frequency at 50% Duty Cycle (kHz)</b>	<b>Filter Setting (ms)</b>	<b>Minimum ON Delay (ms)</b>	<b>Maximum ON Delay (ms)</b>	<b>Minimum OFF Delay (ms)</b>	<b>Maximum OFF Delay (ms)</b>
1.000	0.500	0.090	0.500	0.020	0.500
0.500	1.000	0.500	1.000	0.400	1.000
0.250	2.000	1.100	2.000	1.300	2.000
0.125	4.000	2.800	4.000	2.700	4.000
0.063	8.000 <sup>(1)</sup>	5.800	8.000	5.300	8.000
0.031	16.000	11.000	16.000	10.000	16.000

(1) This is the default setting.



**IMPORTANT**

The relay current must stay within the limits defined in Tables A.5 and A.6.

**Table A.5 Relay Contact Rating Table 1764-24AWA, -24BWA, -28BXB**

Maximum Volts	Amperes		Amperes Continuous	Voltamperes	
	Make	Break		Make	Break
240V ac	7.5A	0.75A	2.5A	1800VA	180VA <sup>(2)</sup>
120V ac	15A	1.5A			
125V dc	0.22A <sup>(1)</sup>		1.0A	28VA	
24V dc	1.2A <sup>(1)</sup>		2.0A	28VA	

(1) For dc voltage applications, the make/break ampere rating for relay contacts can be determined by dividing 28 VA by the applied dc voltage. For example, 28 VA/48V dc = 0.58A. For dc voltage applications less than 14V, the make/break ratings for relay contacts cannot exceed 2A.

(2) The total load controlled by the 1764-24AWA and 1764-24BWA is limited to 1440VA (break).

**Table A.6 Output Specifications - Maximum Continuous Relay Current**

Specification		1764-24AWA, -24BWA	1764-28BXB
Current per Common		8A	8A
Current per Controller	at 150V Maximum	24A	18A
	at 240V Maximum	20A	18A

**Table A.7 1764-28BXB FET Output Specifications**

Specification		General Operation (Outputs 2 thru 7)	High Speed Operation <sup>(1)</sup> (Outputs 2 and 3 Only)
User Supply Voltage	minimum	20.4V dc	20.4V dc
	maximum	26.4V dc	26.4V dc
On-State Voltage Drop	at maximum load current	1V dc	Not Applicable
	at maximum surge current	2.5V dc	Not Applicable
Current Rating per Point	maximum load	1A at 55°C (131°F) 1.5A at 30°C (86°F)	100 mA
	minimum load	1.0 mA	10 mA
	maximum leakage	1.0 mA	1.0 mA

**Table A.7 1764-28BXB FET Output Specifications**

Specification		General Operation (Outputs 2 thru 7)	High Speed Operation <sup>(1)</sup> (Outputs 2 and 3 Only)
Surge Current per Point	peak current	4.0A	Not Applicable
	maximum surge duration	10 msec	Not Applicable
	maximum rate of repetition at 30°C (86°F)	once every second	Not Applicable
	maximum rate of repetition at 55°C (131°F)	once every 2 seconds	Not Applicable
Current per Common	maximum total	6A	Not Applicable
On-State Current	minimum	2.5 mA at 14V dc	2.0 mA at 10V dc
Off-State Leakage Current	maximum	1 mA	1 mA
Turn-On Time	maximum	0.1 msec	6 µsec
Turn-Off Time	maximum	1.0 msec	18 µsec
Repeatability	maximum	n/a	2 µsec
Drift	maximum	n/a	1 µsec per 5°C (1 µsec per 9°F)

(1) Outputs 2 and 3 are designed to provide increased functionality over the other FET outputs (4 through 7). They may be used like the other FET transistor outputs, but in addition, within a limited current range, they may be operated at a higher speed. Outputs 2 and 3 also provide a pulse train output (PTO) or pulse width modulation output (PWM) function.

**Table A.8 Working Voltage (1764-24AWA)**

<b>Specification</b>	<b>1764-24AWA</b>
Power Supply Input to Backplane Isolation	Verified by one of the following dielectric tests: 1836V ac for 1 second or 2596V dc for 1 second
	265V Working Voltage (IEC Class 2 reinforced insulation)
Input Group to Backplane Isolation and Input Group to Input Group Isolation	Verified by one of the following dielectric tests: 151V ac for 1 second or 2145V dc for 1 second
	132V Working Voltage (IEC Class 2 reinforced insulation)
Output Group to Backplane Isolation	Verified by one of the following dielectric tests: 1836V ac for 1 second or 2596V dc for 1 second
	265V Working Voltage (IEC Class 2 reinforced insulation)
Output Group to Output Group Isolation	Verified by one of the following dielectric tests: 1836V ac for 1 second or 2596V dc for 1 second
	265V Working Voltage (basic insulation) 150V Working Voltage (IEC Class 2 reinforced insulation).

**Table A.9 Working Voltage (1764-24BWA)**

<b>Specification</b>	<b>1764-24BWA</b>
Power Supply Input to Backplane Isolation	Verified by one of the following dielectric tests: 1836V ac for 1 second or 2596V dc for 1 second
	265V Working Voltage (IEC Class 2 reinforced insulation)
Power Supply User 24V Output to Backplane Isolation	Verified by one of the following dielectric tests: 600V ac for 1 second or 848V dc for 1 second
	50V Working Voltage (IEC Class 2 reinforced insulation)
Input Group to Backplane Isolation and Input Group to Input Group Isolation	Verified by one of the following dielectric tests: 1200V ac for 1 second or 1697V dc for 1 second
	75V dc Working Voltage (IEC Class 2 reinforced insulation)
Output Group to Backplane Isolation	Verified by one of the following dielectric tests: 1836V ac for 1 second or 2596V dc for 1 second
	265V Working Voltage (IEC Class 2 reinforced insulation).
Output Group to Output Group Isolation.	Verified by one of the following dielectric tests: 1836V ac for 1 second or 2596V dc for 1 second
	265V Working Voltage (basic insulation) 150V Working Voltage (IEC Class 2 reinforced insulation)

**Table A.10 Working Voltage (1764-28BXB)**

<b>Specification</b>	<b>1764-28BXB</b>
Input Group to Backplane Isolation and Input Group to Input Group Isolation	Verified by one of the following dielectric tests: 1200V ac for 1 second or 1697V dc for 1 second
	75V dc Working Voltage (IEC Class 2 reinforced insulation)
FET Output Group to Backplane Isolation and FET Outputs Group to Group	Verified by one of the following dielectric tests: 1200V ac for 1 second or 1697V dc for 1 second
	75V dc Working Voltage (IEC Class 2 reinforced insulation)
Relay Output Group to Backplane Isolation	Verified by one of the following dielectric tests: 1836V ac for 1 second or 2596V dc for 1 second
	265V Working Voltage (IEC Class 2 reinforced insulation)
Relay Output Group to Relay and FET Output Group Isolation	Verified by one of the following dielectric tests: 1836V ac for 1 second or 2596V dc for 1 second
	265V Working Voltage (basic insulation) 150V Working Voltage (IEC Class 2 reinforced insulation)

### Transistor Output Transient Pulses

Refer to page 3-16 for “Transistor Output Transient Pulses”.

## Controller Dimensions

See page 2-12 for Base Unit Mounting Dimensions.

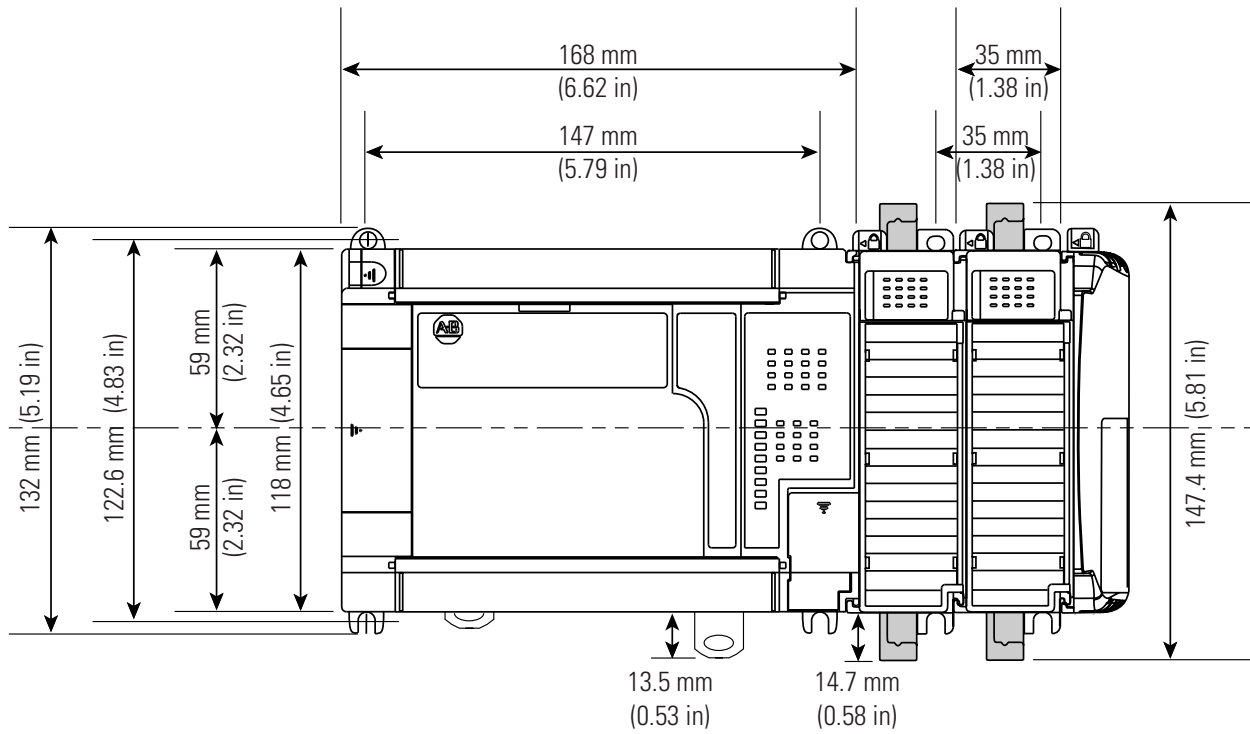

## Compact I/O Dimensions

## Panel Mounting

For more than 2 modules: (number of modules - 1) X 35 mm (1.38 in.)  
 Refer to host controller for this dimension

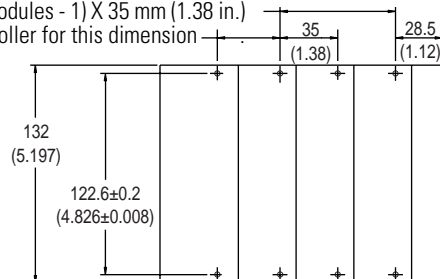

NOTE: All dimensions are in mm (inches).  
 Hole spacing tolerance: ±0.4 mm (0.016 in.)

## End Cap

This illustration shows the 1769-ECR right end cap. For the 1769-ECL left end cap, the drawing would be reversed.

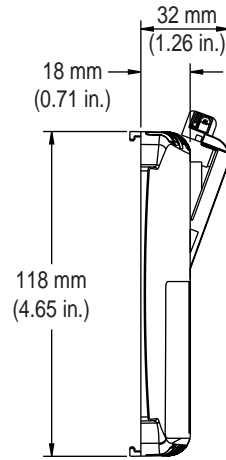

Dimensions are in mm (inches).

## Replacement Parts

This chapter contains the following information:

- a table of MicroLogix 1500 replacement parts
- procedure for replacing the lithium battery
- illustrations of the MicroLogix 1500 replacement doors and terminal blocks

### MicroLogix 1500 Replacement Kits

The table below provides a list of replacement parts and their catalog number.

Description	Catalog Number
Lithium Battery (See page B-2.)	1747-BA
ESD Barrier	1764-RPL-TRM1
Base Terminal Doors (See page B-6.)	1764-RPL-TDR1
Processor Access Door (See page B-6.)	1764-RPL-CDR1
Door Combination Kit, includes ESD Barrier, Terminal Door, Access Door, Base Comms Door (See page B-6.), and Trim Pots/Mode Switch Cover Door (See page B-6.)	1764-RPL-DR
17-Point Terminal Block (for inputs on 1764-24AWA and -24BWA bases) (See page B-5.)	1764-RPL-TB1
21-Point Terminal Block (for inputs of 1764-28BXB and outputs for all base units)(See page B-5.)	1764-RPL-TB2

## Lithium Battery (1747-BA)

### IMPORTANT

When the processor's Battery Low indicator is lit, install a backup battery immediately. After the indicator turns on, the battery lasts for at least:

- 14 days for the 1764-LSP
- 7 days for the 1764-LRP

## Installing

Follow the procedure below to ensure proper replacement battery installation.

### IMPORTANT

Do not remove the permanent battery when installing replacement battery.

1. Insert battery into replacement battery pocket with wires facing up.
2. Insert replacement battery wire connector into connector port.
3. Secure battery wires under wire latch (as shown below).

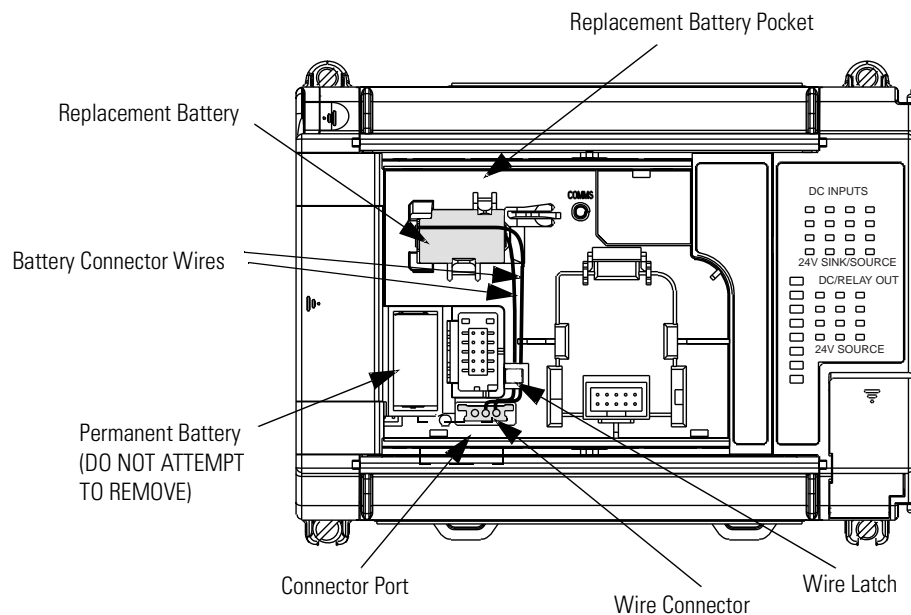



---

## Battery Handling

Follow the procedure below to ensure proper battery operation and reduce personnel hazards.

- Use only for the intended operation.
- Do not ship or dispose of cells except according to recommended procedures.
- Do not ship on passenger aircraft.

---

### ATTENTION



- Do not charge the batteries. An explosion could result or the cells could overheat causing burns.
  - Do not open, puncture, crush, or otherwise mutilate the batteries. A possibility of an explosion exists and/or toxic, corrosive, and flammable liquids would be exposed.
  - Do not incinerate or expose the batteries to high temperatures. Do not attempt to solder batteries. An explosion could result.
  - Do not short positive and negative terminals together. Excessive heat can build up and cause severe burns.
- 

## Storing

Store lithium batteries in a cool, dry environment, typically +20°C to +25°C (+68°F to 77°F) and 40% to 60% humidity. Store the batteries and a copy of the battery instruction sheet in the original container, away from flammable materials.

## Transporting

### *One or Two Batteries*

Each battery contains 0.23 grams of lithium. Therefore, up to two batteries can be shipped together within the United States without restriction. Regulations governing shipment to or within other countries may differ.

### *Three or More Batteries*

Procedures for the transportation of three or more batteries shipped together within the United States are specified by the Department of Transportation (DOT) in the Code of Federal Regulations, CFR49, "Transportation." An exemption to these regulations, DOT - E7052, covers the transport of certain hazardous materials classified as flammable solids. This exemption authorizes transport of lithium batteries by motor vehicle, rail freight, cargo vessel, and cargo-only aircraft, providing certain conditions are met. Transport by passenger aircraft is not permitted.

A special provision of DOT-E7052 (11th Rev., October 21, 1982, par. 8-a) provides that:

"Persons that receive cell and batteries covered by this exemption may reshipe them pursuant to the provisions of 49 CFR 173.22a in any of these packages authorized in this exemption including those in which they were received."

The Code of Federal Regulations, 49 CFR 173.22a, relates to the use of packaging authorized under exemptions. In part, it requires that you must maintain a copy of the exemption at each facility where the packaging is being used in connection with shipment under the exemption.

Shipment of depleted batteries for disposal may be subject to specific regulation of the countries involved or to regulations endorsed by those countries, such as the IATA Articles Regulations of the International Air Transport Association, Geneva, Switzerland.

---

**IMPORTANT**

Regulations for transportation of lithium batteries are periodically revised.

---

### **Disposing**

---

**ATTENTION**

Do not incinerate or dispose of lithium batteries in general trash collection. Explosion or violent rupture is possible. Batteries should be collected for disposal in a manner to prevent against short-circuiting, compacting, or destruction of case integrity and hermetic seal.

---

For disposal, batteries must be packaged and shipped in accordance with transportation regulations, to a proper disposal site. The U.S. Department of Transportation authorizes shipment of "Lithium batteries for disposal" by motor vehicle only in regulation 173.1015 of CFR 49 (effective January 5, 1983). For additional information contact:

U.S. Department of Transportation  
Research and Special Programs Administration  
400 Seventh Street, S.W.  
Washington, D.C. 20590

Although the Environmental Protection Agency at this time has no regulations specific to lithium batteries, the material contained may be considered toxic, reactive, or corrosive. The person disposing of the material is responsible for any hazard created in doing so. State and local regulations may exist regarding the disposal of these materials.

For a lithium battery product safety data sheet, contact the manufacturer:

Sanyo Energy Corporation  
2001 Sanyo Avenue  
San Diego, CA 92173  
(619) 661-4801

Tadarand Electronic Industries  
2 Seaview Blvd.  
Port Washington, NY 11050  
(516) 621-4980

## Replacement Terminal Blocks

This figure illustrates how to replace the MicroLogix 1500 terminal blocks.

Catalog Numbers:

- 1764-RPL-TB1: 17-point terminal block
- 1764-RPL-TB2: 21-point terminal block

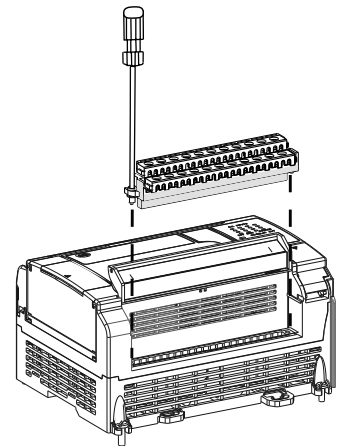

## Replacement Doors

The following figures illustrate the procedure for installing the MicroLogix 1500 replacement doors.

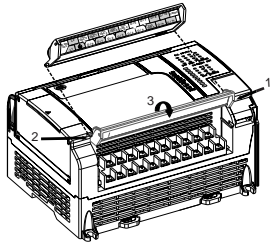
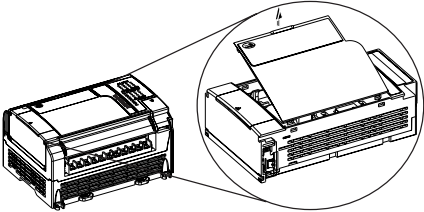
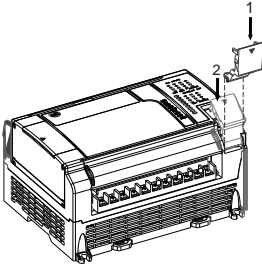
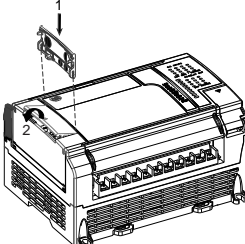
<b>Base Terminal Door (1764-RPL-TDR1)</b>	 A perspective view of the MicroLogix 1500 base unit with the terminal door open. Callout 1 points to the top edge of the door, callout 2 points to the bottom edge, and callout 3 points to the terminal block area.
<b>Processor Access Door (1764-RPL-CDR1)</b>	 A perspective view of the MicroLogix 1500 base unit with the processor access door open. A circular inset provides a magnified view of the door's top edge, with callout 4 pointing to a specific feature.
<b>Base Comms Door (included in 1764-RPL-DR)</b>	 A perspective view of the MicroLogix 1500 base unit with the base comms door open. Callout 1 points to the top edge of the door, and callout 2 points to the bottom edge.
<b>Trim Pots/Mode Switch Cover Door (included in 1764-RPL-DR)</b>	 A perspective view of the MicroLogix 1500 base unit with the trim pots cover door open. Callout 1 points to the top edge of the door, and callout 2 points to the bottom edge.

## Troubleshooting Your System

This chapter

describes how to troubleshoot your controller. Topics include:

- understanding the controller LED status
- controller error recovery model
- identifying controller faults
- calling Rockwell Automation for assistance

### Understanding Controller LEDs

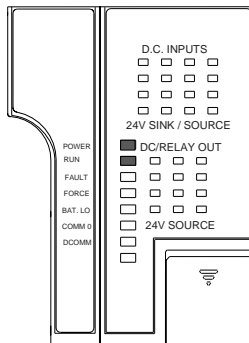

The controller status LEDs provide a mechanism to determine the current status of the controller if a programming device is not present or available.

LED	Color	Indicates
POWER	off	no input power
	green	power on
RUN	off	controller is not in Run mode or REM Run
	green	controller is in Run mode or REM Run
	green flashing	system is not in Run mode; memory module transfer is in progress
FAULT	off	no fault detected
	red flashing	faulted user program
	red	processor hardware fault or critical fault
FORCE	off	no forces installed
	amber	forces installed
BATTERY LOW	off	battery OK
	red	battery needs replacement (See page B-2.)
COMM 0	off	flashes when communications are active
	green	
COMM 1 (1764-LRP only)	off	flashes when communications are active
	green	
DCOMM <sup>(1)</sup>	off	user configured communications mode is active
	green	default communications mode active

LED	Color	Indicates
INPUTS	off	input is not energized
	amber	input is energized (logic status)
OUTPUTS	off	output is not energized
	amber	output is energized (logic status)

(1) When using a 1764-LRP processor, the DCOMM LED applies only to Channel 0.

## When Operating Normally

The POWER and RUN LEDs are on. If a force condition is active, the FORCE LED turns on and remains on until all forces are removed.

## When an Error Exists

If an error exists within the controller, the controller LEDs operate as described in the following tables.

If the LED indicate:	The Following Error Exists	Probable Cause	Recommended Action
All LEDS off	No input power or power supply error	No Line Power	Verify proper line voltage and connections to the controller.
		Power Supply Overloaded	This problem can occur intermittently if power supply is overloaded when output loading and temperature varies.
Power and FAULT LEDS on solid	Hardware faulted	Processor Hardware Error	Cycle power. Contact your local Rockwell Automation representative if the error persists.
		Loose Wiring	Verify connections to the controller.
Power LED on and FAULT LED flashing	Application fault	Hardware/Software Major Fault Detected	<ol style="list-style-type: none"> <li>1. Monitor Status File Word S:6 for major error code. See page C-5 for more information.</li> <li>2. Remove hardware/software condition causing fault.</li> <li>3. Clear Major Error Halted flag, bit S2:1/13.</li> <li>4. Attempt a controller Run mode entry. If unsuccessful, repeat recommended action steps above or contact your local Rockwell Automation distributor.</li> </ol>

## Controller Error Recovery Model

Use the following error recovery model to help you diagnose software and hardware problems in the micro controller. The model provides common questions you might ask to help troubleshoot your system. Refer to the recommended pages within the model for further help.

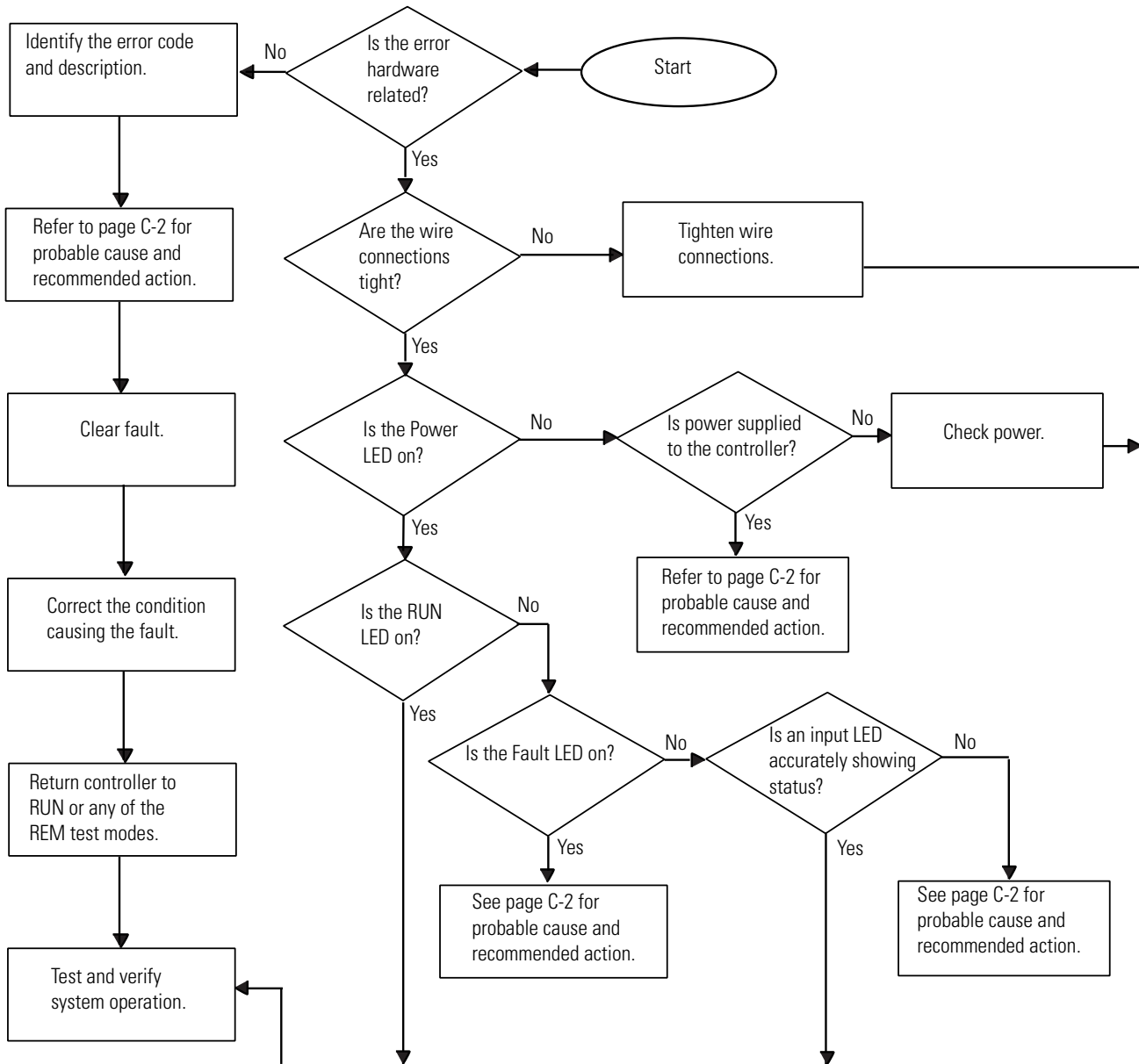

## Identifying Controller Faults

While a program is executing, a fault may occur within the operating system or your program. When a fault occurs, you have various options to determine what the fault is and how to correct it. This section describes how to clear faults and provides a list of possible advisory messages with recommended corrective actions.

### Automatically Clearing Faults

You can automatically clear a fault by cycling power to the controller when the Fault Override at Power-up bit (S:1/8) is set in the status file.

You can also configure the controller to clear faults and go to RUN every time the controller is power cycled. This is a feature that OEMs can build into their equipment to allow end users to reset the controller. If the controller faults, it can be reset by simply cycling power to the machine. To accomplish this, set the following bits in the status file:

- S2:1/8 - Fault Override at Power-up
- S2:1/12 - Mode Behavior

If the fault condition still exists after cycling power, the controller re-enters the fault mode. For more information on status bits, refer to the *MicroLogix 1200 and MicroLogix 1500 Instruction Set Reference Manual*, publication 1762-RM001.

**TIP**

You can declare your own application-specific major fault by writing your own unique value to S:6 and then setting bit S:1/13 to prevent reusing system defined codes. The recommended values for user defined faults are FF00 to FF0F.

### Manually Clearing Faults Using the Fault Routine

The occurrence of recoverable or non-recoverable user faults can cause the user fault subroutine to be executed. If the fault is recoverable, the subroutine can be used to correct the problem and clear the fault bit S:1/13. The controller then continues in the Run or test mode.

The subroutine does not execute for non-user faults. Refer to the *MicroLogix 1200 and MicroLogix 1500 Instruction Set Reference*



*Manual*, publication 1762-RM001, for information on creating a user fault subroutine.

## **Fault Messages**

Refer to the *MicroLogix 1200 and 1500 Instruction Set Reference Manual*, publication 1762-RM001, for the controller fault messages that can occur during operation of the MicroLogix 1500 programmable controllers. Each fault message includes the error code description, the probable cause, and the recommended corrective action.

## **Calling Rockwell Automation for Assistance**

If you need to contact Rockwell Automation or local distributor for assistance, it is helpful to obtain the following (prior to calling):

- controller type, series letter, and revision letter of the base unit
- series letter, revision letter, and firmware (FRN) number of the processor (on bottom side of processor unit)
- controller LED status
- controller error codes (found in S2:6 of status file).



## Upgrading Your Operating System

The operating system (OS) can be upgraded through the communication port on the controller. In order to download a new operating system, you must have the following:

- ControlFLASH™ Upgrade Kit containing the new OS
- a Windows® 95, Windows® 98, Windows NT™, or Windows® 2000 based computer to run the download software.

The ControlFLASH™ Upgrade Kit includes:

- the operating system upgrade to be downloaded
- the ControlFLASH programming tool, along with its support drivers and on-line help
- a readme first file explaining how to upgrade the operating system

### Preparing for Upgrade

Before upgrading the controller's operating system, you must:

- Obtain the operating system upgrade from <http://www.ab.com/micrologix> or from your local Allen-Bradley distributor

---

**IMPORTANT**

Installing a new operating system deletes the controller's user program.

---

- Install the ControlFlash Software. Double click the processor catalog number/firmware revision number to install the operating system upgrade.
- The controller must be configured for default communications (use communications toggle push button; DCOMM LED on) and be in the Program mode to allow the download of a new operating system.

## Performing the Upgrade

The following steps occur during the upgrade process.

1. Controller mode and communications parameters are checked.
2. Download begins.
3. During the download, the Force, Battery, and Comms LEDs perform a walking bit pattern.
4. When the download is complete, the integrity of the new OS is checked. If the new OS is corrupt, the controller sends an error message to the computer and flashes the Missing or Corrupt OS LED pattern. See Missing/Corrupt OS LED Pattern below.
5. Following a successful transfer, the Power, Force, and Battery LEDs flash on and remain on for five seconds. Then the controller resets.

## Missing/Corrupt OS LED Pattern

When an operating system download is not successful or if the controller does not contain a valid operating system, the controller flashes the Run, Force, and Fault LEDs on and off.

## Understanding Communication Protocols

Use the information in this appendix to understand the differences in communication protocols. The following protocols are supported from the RS-232 communication channel:

- DF1 Full-Duplex
- DF1 Half-Duplex Slave
- DH-485
- Modbus RTU Slave (1764-LSP and 1764-LRP Series B Processors only)
- ASCII (1764-LSP and 1764-LRP Series B Processors only)

See Chapter 4 for information about required network devices and accessories.

### RS-232 Communication Interface

The communications port on the MicroLogix 1500 utilizes an RS-232 interface. RS-232 is an Electronics Industries Association (EIA) standard that specifies the electrical characteristics for serial binary communication. It provides you with a variety of system configuration possibilities. (RS-232 defines electrical characteristics; it is *not* a protocol.)

One of the biggest benefits of an RS-232 interface is that it lets you easily integrate telephone and radio modems into your control system.

### DF1 Full-Duplex Protocol

DF1 Full-Duplex protocol is an open protocol developed by Allen-Bradley. It provides a point-to-point connection between two devices. DF1 Full-Duplex protocol combines data transparency (American National Standards Institute ANSI - X3.28-1976 specification subcategory D1) and 2-way simultaneous transmission with embedded responses (subcategory F1). Refer to *DF1 Protocol and Command Set Reference Manual*, publication 1770-6.5.16, for more information.

DF1 Full-Duplex protocol (also referred to as DF1 point-to-point protocol) is useful where RS-232 point-to-point communication is required. DF1 protocol controls message flow, detects and signals errors, and retries if errors are detected.

MicroLogix 1500 controllers support the DF1 Full-Duplex protocol via RS-232 connection to external devices such as computers, controllers, and other interface devices that support DF1 Full-Duplex.

For information about required network connecting equipment and examples of DF1 Full-Duplex connections, see Chapter 4.

## **DF1 Half-Duplex Protocol**

DF1 Half-Duplex protocol is a multi-drop single master/multiple slave network. DF1 Half-Duplex protocol supports data transparency (American National Standards Institute ANSI - X3.28-1976 specification subcategory D1). In contrast to DF1 Full-Duplex, communication takes place in one direction at a time. With an active Half-Duplex Master, you can use the RS-232 port on the MicroLogix 1500 as a Half-Duplex programming port and a Half-Duplex peer-to-peer messaging port.

### **DF1 Half-Duplex Operation**

A DF1 Half-Duplex master device initiates all communication by “polling” each slave device. The slave device may only transmit when it is polled by the master. It is the master’s responsibility to poll each slave on a regular and sequential basis to allow slave devices an opportunity to communicate.

An additional feature of the DF1 Half-Duplex protocol is that it is possible for a slave device to enable a MSG write or read to/from another slave. When the initiating slave is polled, the MSG is sent to the master. The master recognizes that the message is not intended for it, but for another slave, so the master immediately forwards the message to the intended slave. The master does this automatically; you do not need to program the master to move data between slave nodes. This slave-to-slave transfer can also be used by programming software to allow slave-to-slave upload and download of programs to processors (including the master) on the DF1 Half-Duplex link.

The MicroLogix 1500 can only act as a slave device. A device that can act as a master is required to “run” the network. Several Allen-Bradley products support DF1 Half-Duplex master protocol. They include the SLC 5/03™ and higher processors, enhanced PLC-5® processors, and Rockwell Software RSLinx (version 2.x and higher).

DF1 Half-Duplex supports up to 255 devices (address 0 to 254) with address 255 reserved for master broadcasts. The MicroLogix 1500 supports broadcast reception.

---

## Considerations When Communicating as a DF1 Slave on a Multi-drop Link

When communication is between either your programming software and a MicroLogix Programmable Controller or between two MicroLogix 1500 Programmable Controllers via slave-to-slave communication on a larger multi-drop link, the devices depend on a DF1 Half-Duplex Master to give each of them access in a timely manner. As the number of slave devices increase, the time between when slave devices are polled also increases. This increase in time may also be large if you are using low baud rates. As these time periods grow, you may need to increase the poll timeout and reply timeout values for slave devices.

---

**IMPORTANT**

If a program download is started when using DF1 Half-Duplex, but then is interrupted due to electromagnetic interference or other events, discontinue communications to the controller for the *ownership timeout* period and then restart the program download. The *ownership timeout* period is 60 seconds. After the timeout, you can re-establish communications with the processor and try the program download again. The only other way to remove program ownership is to cycle power on the processor.

---

## Using Modems with MicroLogix 1500 Programmable Controllers

The types of modems that you can use with MicroLogix 1500 controllers include dial-up phone modems, leased-line modems, radio modems and line drivers.

For point-to-point Full-Duplex modem connections that do not require any modem handshaking signals to operate, use DF1 Full-Duplex protocol with no handshaking. For point-to-point Full-Duplex modem connections that require RTS/CTS handshaking, use DF1 Full-Duplex protocol with handshaking.

For multi-drop modem connections, or for point-to-point modem connections that require RTS/CTS handshaking, use DF1 Half-Duplex slave protocol.

---

**IMPORTANT**

Never attempt to use DH-485 protocol through modems under any circumstance.

---

**TIP**



All MicroLogix controllers support RTS/CTS modem handshaking when configured for DF1 Full-Duplex protocol with the control line parameter set to Full-Duplex Modem Handshaking or DF1 Half-Duplex slave protocol with the control line parameter set to “Half-Duplex Modem”. No other modem handshaking lines (i.e. Data Set Ready, Carrier Detect and Data Terminal Ready) are supported by any MicroLogix 1500 controllers. MicroLogix 1500 1764-LRP processors also support DCD (Data Carrier Detect)

## Dial-Up Phone Modems

Some dial-up phone line modems support point-to-point Full-Duplex communications. A MicroLogix 1500 controller, on the receiving end of the dial-up connection, can be configured for DF1 Full-Duplex protocol with or without handshaking. The modem connected to the MicroLogix controller should support auto-answer. The MicroLogix 1500 Series B processors (1764-LSP and 1764-LRP) support ASCII out communications. Therefore, they can cause the modem to initiate or disconnect a phone call.

## Leased-Line Modems

Leased-line modems are used with dedicated phone lines that are typically leased from the local phone company. The dedicated lines may be in a point-to-point topology supporting Full-Duplex communications between two modems or in a multi-drop topology supporting Half-Duplex communications between three or more modems.



## Radio Modems

Radio modems may be implemented in a point-to-point topology supporting either Half-Duplex or Full-Duplex communications, or in a multi-drop topology supporting Half-Duplex communications between three or more modems.

## Line Drivers

Line drivers, also called short-haul “modems”, do not actually modulate the serial data, but rather condition the electrical signals to operate reliably over long transmission distances (up to several miles). Line drivers are available in Full- and Half-Duplex models. Allen-Bradley’s AIC+ Advanced Interface Converter is a Half-Duplex line driver that converts an RS-232 electrical signal into an RS-485 electrical signal, increasing the signal transmission distance from 50 to 4000 feet (8000 feet when bridged).

## DH-485 Communication Protocol

The information in this section describes DH-485 network functions, network architecture, and performance characteristics. It will also help you plan and operate the MicroLogix controllers on a DH-485 network.

### DH-485 Network Description

The DH-485 protocol defines the communication between multiple devices that coexist on a single pair of wires. DH-485 protocol uses RS-485 Half-Duplex as its physical interface. (RS-485 is a definition of electrical characteristics; it is *not* a protocol.) RS-485 uses devices that are capable of co-existing on a common data circuit, thus allowing data to be easily shared between devices.

The DH-485 network offers:

- interconnection of 32 devices
- multi-master (peer-to-peer) capability
- token passing access control
- the ability to add or remove nodes without disrupting the network
- maximum network segment of 1219 m (4000 ft)

The DH-485 protocol supports two classes of devices: initiators and responders. All initiators on the network get a chance to initiate message transfers. To determine which initiator has the right to transmit, a token passing algorithm is used.

The following section describes the protocol used to control message transfers on the DH-485 network.

## DH-485 Token Rotation

A node holding the token can send a message onto the network. Each node is allowed a fixed number of transmissions (based on the Token Hold Factor) each time it receives the token. After a node sends a message, it passes the token to the next device.

The allowable range of node addresses is 1 to 31. There must be at least one initiator on the network (such as a MicroLogix controller, or an SLC 5/02™ or higher processor).

## DH-485 Configuration Parameters

When MicroLogix communications are configured for DH-485, the following parameters can be changed:

**Table E.1 DF1 Full-Duplex Configuration Parameters**

<b>Parameter</b>	<b>Options</b>
Baud Rate	9600, 19.2K
Node Address	1 to 31 decimal
Token Hold Factor	1 to 4

See Software Considerations on page E-10 for tips on setting the parameters listed above.

## Devices that Use the DH-485 Network

In addition to the MicroLogix 1500 controllers, the devices shown in the following table also support the DH-485 network.

**Table E.2 Allen-Bradley Devices that Support DH-485 Communication**

Catalog Number	Description	Installation	Function	Publication
Bulletin 1761 Controllers	MicroLogix 1000	Series C or higher	These controllers support DH-485 communications.	1761-6.3
Bulletin 1762	MicroLogix 1200	Series A or higher	These controllers support DH-485 communications.	1762-UM001
Bulletin 1747 Processors	SLC 500 Processors	SLC Chassis	These processors support a variety of I/O requirements and functionality.	1747-6.2
1746-BAS	BASIC Module	SLC Chassis	Provides an interface for SLC 500 devices to foreign devices. Program in BASIC to interface the 3 channels (2 RS232 and 1 DH-485) to printers, modems, or the DH-485 network for data collection.	1746-6.1 1746-6.2 1746-6.3
1785-KA5	DH+™/ DH-485 Gateway	(1771) PLC Chassis	Provides communication between stations on the PLC-5® (DH+) and SLC 500 (DH-485) networks. Enables communication and data transfer from PLC® to SLC 500 on DH-485 network. Also enables programming software programming or data acquisition across DH+ to DH-485.	1785-6.5.5 1785-1.21
2760-RB	Flexible Interface Module	(1771) PLC Chassis	Provides an interface for SLC 500 (using protocol cartridge 2760-SFC3) to other A-B PLCs and devices. Three configurable channels are available to interface with Bar Code, Vision, RF, Dataliner™, and PLC systems.	1747-KE 2760-ND001
1784-KTX, -KTXD	PC DH-485 IM	IBM XT/AT Computer Bus	Provides DH-485 using RSLinx.	1784-6.5.22
1784-PCMK	PCMCIA IM	PCMCIA slot in computer and Interchange	Provides DH-485 using RSLinx.	1784-6.5.19

**Table E.2 Allen-Bradley Devices that Support DH-485 Communication**

<b>Catalog Number</b>	<b>Description</b>	<b>Installation</b>	<b>Function</b>	<b>Publication</b>
1747-PT1	Hand-Held Terminal	NA	Provides hand-held programming, monitoring, configuring, and troubleshooting capabilities for SLC 500 processors.	1747-NP002
1747-DTAM, 2707-L8P1, -L8P2, -L40P1, -L40P2, -V40P1, -V40P2, -V40P2N, -M232P3, and -M485P3	DTAM, DTAM Plus, and DTAM Micro Operator Interfaces	Panel Mount	Provides electronic operator interface for SLC 500 processors.	1747-ND013 2707-800, 2707-803
2711-K5A2, -B5A2, -K5A5, -B5A5, -K5A1, -B5A1, -K9A2, -T9A2, -K9A5, -T9A5, -K9A1, and -T9A1	PanelView 550 and PanelView 900 Operator Terminals	Panel Mount	Provides electronic operator interface for SLC 500 processors.	2711-802, 2711-816

NA = Not Applicable

## Important DH-485 Network Planning Considerations

Carefully plan your network configuration before installing any hardware. Listed below are some of the factors that can affect system performance:

- amount of electrical noise, temperature, and humidity in the network environment
- number of devices on the network
- connection and grounding quality in installation
- amount of communication traffic on the network
- type of process being controlled
- network configuration

The major hardware and software issues you need to resolve before installing a network are discussed in the following sections.

### *Hardware Considerations*

You need to decide the length of the communication cable, where you route it, and how to protect it from the environment where it will be installed.

When the communication cable is installed, you need to know how many devices are to be connected during installation and how many devices will be added in the future. The following sections will help you understand and plan the network.

#### *Number of Devices and Length of Communication Cable*

The maximum length of the communication cable is 1219m (4000 ft). This is the total cable distance from the first node to the last node in a segment. However, two segments can be used to extend the DH-485 network to 2438m (8000 ft). for additional information on connections using the AIC+, refer to the *Advanced Interface Converter (AIC+) User Manual*, publication 1761-6.4.

#### *Planning Cable Routes*

Follow these guidelines to help protect the communication cable from electrical interference:

- Keep the communication cable at least 1.52m (5 ft) from any electric motors, transformers, rectifiers, generators, arc welders, induction furnaces, or sources of microwave radiation.
- If you must run the cable across power feed lines, run the cable at right angles to the lines.
- If you do not run the cable through a contiguous metallic wireway or conduit, keep the communication cable at least 0.15m (6 in.) from ac power lines of less than 20A, 0.30m (1 ft) from lines greater than 20A, but only up to 100 kVA, and 0.60m (2 ft) from lines of 100 kVA or more.
- If you run the cable through a contiguous metallic wireway or conduit, keep the communication cable at least 0.08m (3 in.) from ac power lines of less than 20A, 0.15m (6 in.) from lines greater than 20A, but only up to 100 kVA, and 0.30m (1 ft) from lines of 100 kVA or more.

Running the communication cable through conduit provides extra protection from physical damage and electrical

interference. If you route the cable through conduit, follow these additional recommendations:

- Use ferromagnetic conduit near critical sources of electrical interference. You can use aluminum conduit in non-critical areas.
- Use plastic connectors to couple between aluminum and ferromagnetic conduit. Make an electrical connection around the plastic connector (use pipe clamps and the heavy gauge wire or wire braid) to hold both sections at the same potential.
- Ground the entire length of conduit by attaching it to the building earth ground.
- Do not let the conduit touch the plug on the cable.
- Arrange the cables loosely within the conduit. The conduit should contain only serial communication cables.
- Install the conduit so that it meets all applicable codes and environmental specifications.

For more information on planning cable routes, see *Industrial Automation Wiring and Grounding Guidelines*, publication 1770-4.1.

### *Software Considerations*

Software considerations include the configuration of the network and the parameters that can be set to the specific requirements of the network. The following are major configuration factors that have a significant effect on network performance:

- number of nodes on the network
- addresses of those nodes
- baud rate

The following sections explain network considerations and describe ways to select parameters for optimum network performance (speed). See your programming software's user manual for more information.

### *Number of Nodes*

The number of nodes on the network directly affects the data transfer time between nodes. Unnecessary nodes (such as a second programming terminal that is not being used) slow the data transfer rate. The maximum number of nodes on the network is 32.

### *Setting Node Addresses*

The best network performance occurs when node addresses are assigned in sequential order. Initiators, such as personal computers, should be assigned the lowest numbered addresses to minimize the time required to initialize the network. The valid range for the MicroLogix 1500 controllers is 1-31 (controllers cannot be node 0). The default setting is 1. The node address is stored in the controller Communications Status file (CS0:5/0 to CS0:5/7).

### *Setting Controller Baud Rate*

The best network performance occurs at the highest baud rate, which is 19200. This is the default baud rate for a MicroLogix 1500 device on the DH-485 network. All devices must be at the same baud rate. This rate is stored in the controller Communications Status file (CS0:5/8 to CS0:5/15).

### *Setting Maximum Node Address*

Once you have an established network set up and are confident that you will not be adding more devices, you may enhance performance by adjusting the maximum node address of your controllers. It should be set to the highest node address being used.

---

**IMPORTANT**

All devices should be set to the same maximum node address.

---

### *MicroLogix Remote Packet Support*

MicroLogix 1500 controllers can respond and initiate with device's communications (or commands) that do not originate on the local DH-485 network. This is useful in installations where communication is needed between the DH-485 and DH+ networks.

The example below shows how to send messages from a PLC device or a PC on the DH+ network to a MicroLogix controller on the DH-485 network. This method uses an SLC 5/04 processor bridge connection.

When using this method (as shown in the following illustration):

- PLC-5 devices can send read and write commands to MicroLogix 1500 controllers.
- MicroLogix 1500 controllers can respond to MSG instructions received.
- The MicroLogix 1500 controllers can initiate MSG instructions to devices on the DH+ network.
- PC can send read and write commands to MicroLogix 1500 controllers.
- PC can do remote programming of MicroLogix 1500 controllers.

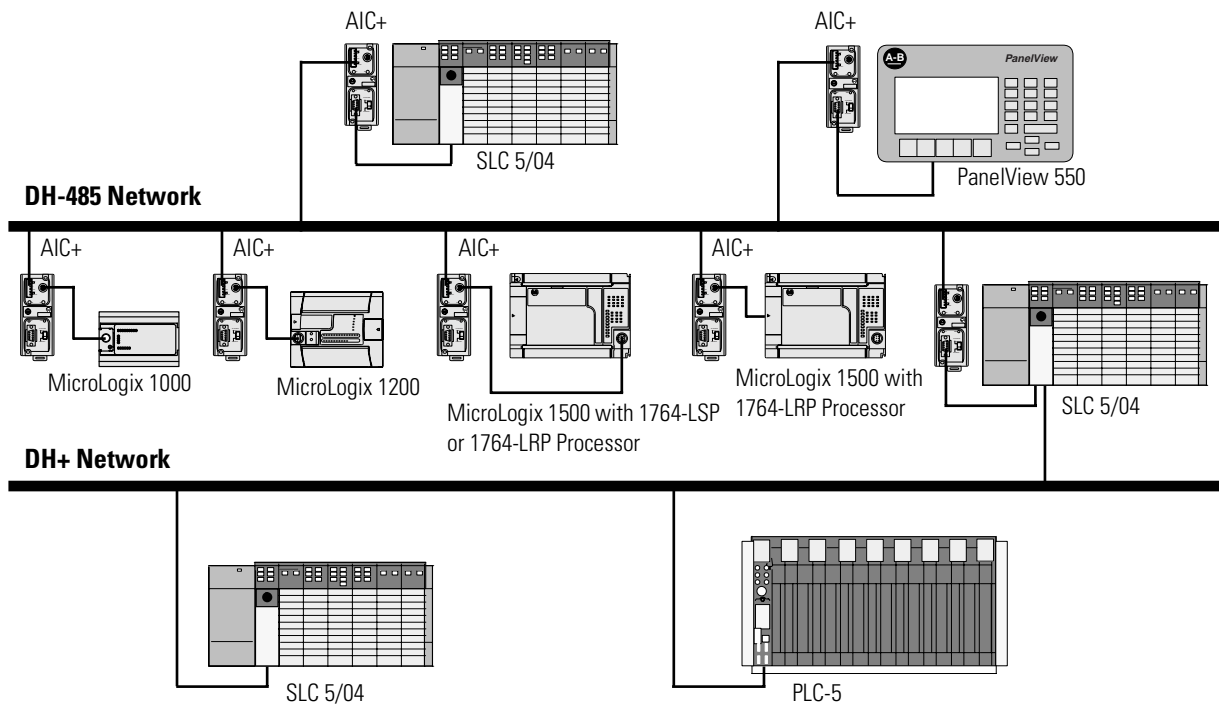



## Modbus RTU Slave Communication Protocol (MicroLogix 1764-LSP and 1764-LRP Series B and later processors only)

Modbus RTU Slave is a Half-Duplex, master-slave communications protocol. The Modbus network master initiates and controls all communications on the network. Modbus protocol allows a single master to communicate with a maximum of 255 slave devices.

When a MicroLogix 1200 or 1500 Communications port is configured for Modbus RTU Slave operation, the user must define where Modbus data (coils, contacts, and registers) is mapped into the MicroLogix data space.

The Modbus address space is comprised of seven distinct memory ranges. Four of these ranges can be mapped into MicroLogix data files. Three Modbus ranges are fixed to MicroLogix file 2, the Status file. The table below illustrates Modbus to MicroLogix mappings.

**Table E.3 Modbus to MicroLogix Memory Map**

Modbus Addressing	Description	Valid MicroLogix Addressing		
		File Type	Data File Number	Address
0001 to 4096	Read/Write Modbus Coil Data space	Bit (B) or Integer (N)	3 to 255	bits 0 to 4095
10001 to 14096	Read-Only Modbus Contact Data space	Bit (B) or Integer (N)	3 to 255	bits 0 to 4095
30001 to 30256	Read-Only Modbus Input Register space	Bit (B) or Integer (N)	3 to 255	words 0 to 255
30501 to 30532	Modbus Communication Parameters	Communication Status Files	2	words 0 to 31
31501 to 31566	Read-Only System Status File space	Status (S)	2	words 32 to 65
40001 to 40256	Read/Write Modbus Holding Register space	Bit (B) or Integer (N)	3 to 255	words 0 to 255
41501 to 41566	Read/Write System Status File space	Status (S)	2	words 0 to 65

For more information on the MicroLogix 1500 configuration parameters for Modbus Slave RTU (Remote Terminal Unit transmission mode) protocol, refer to the MicroLogix 1200 and 1500 Programmable Controllers Instruction Set Reference Manual, publication 1762-RM001. For more information about the Modbus Slave protocol, see the Modbus Protocol Specifications (available from <http://www.modicon.com/techpubs/>).

## ASCII Protocol (MicroLogix 1500 1764-LSP and 1764-LRP Series B and later Processors only)

ASCII protocol provides connection to other ASCII devices, such as bar code readers, weigh scales, serial printers, and other intelligent devices.

You can use ASCII protocol by configuring the RS-232 port, channel 0 for ASCII driver (*For the 1764-LRP only, you can select either Channel 0 or Channel 1*).

Refer to the *MicroLogix 1200 and MicroLogix 1500 Programmable Controllers Instruction Set Reference Manual*, publication 1762-RM001 for detailed configuration information.

When the driver is set to ASCII, the following parameters can be changed:

**Table E.4 ASCII Channel Configuration Parameters**

Parameter	Description	Programming Software Default
Baud Rate	Toggles between the communication rate of 300, 600, 1200, 2400, 4800, 9600, 19.2K, and 38.4K.	1200
Parity	Toggles between None, Odd, and Even.	None
Termination 1	Specifies the first termination character. The termination character defines the one or two character sequence used to specify the end of an ASCII line received. Setting the first ASCII termination character to undefined (\ff) indicates no ASCII receiver line termination is used.	\d
Termination 2	Specifies the second termination character. The termination character defines the one or two character sequence used to specify the end of an ASCII line received. Setting the second ASCII Termination character to undefined (\ff) and the first ASCII Termination character to a defined value (\d) indicates a single character termination sequence.	\ff
Control Line	Toggles between No Handshaking, Half-Duplex Modem, and Full-Duplex Modem	No Handshaking
Delete Mode	The Delete Mode allows you to select the mode of the "delete" character. Toggles between Ignore, CRT, and Printer. Delete Mode affects the characters echoed back to the remote device. When Delete Mode is enabled, the previous character is removed from the receive buffer. <ul style="list-style-type: none"> <li>In CRT mode, when a delete character is encountered, the controller echos three characters to the device: backspace, space, and backspace. This erases the previous character on the terminal.</li> <li>In Printer Mode, when a delete character is encountered, the controller echos the slash character, then the deleted character.</li> </ul> Enable the Echo parameter to use Delete Mode.	Ignore
Echo	When Echo Mode is enabled, all of the characters received are echoed back to the remote device. This allows you to view characters on a terminal connected to the controller. Toggles between Enabled and Disabled.	Disabled
XON/XOFF	Allows you to Enable or Disable XON/ XOFF software handshaking. XON/XOFF software handshaking involves the XON and XOFF control characters in the ASCII character set. When the receiver receives the XOFF character, the transmitter stops transmitting until the receiver receives the XON character. If the receiver does not receive an XON character after 60 seconds, the transmitter automatically resumes sending characters. Also, when the receive buffer is more than 80% full, an XOFF character is sent to the remote device to pause the transmission. Then, when the receive buffer drops to less than 80% full, an XON character is sent to the remote device to resume the transmission.	Disabled
RTS Off Delay (x20 ms)	Allows you to select the delay between when a transmission is ended and when RTS is dropped. Specify the RTS Off Delay value in increments of 20 ms. Valid range is 0 to 65535.	0
RTS Send Delay (x20 ms)	Allows you to select the delay between when RTS is raised and the transmission is initiated. Specify the RTS Send Delay value in increments of 20 ms. Valid range is 0 to 65535.	0

---

## System Loading and Heat Dissipation

### System Loading Limitations

When you connect MicroLogix accessories and expansion I/O, an electrical load is placed on the base unit power supply. This section shows how to calculate the load and validate that the system will not exceed the capacity of the base unit power supply or expansion power supply.

The following example is provided to illustrate system loading validation. The system validation procedure accounts for the amount of 5V dc and 24V dc current consumed by controller, expansion I/O, and user supplied equipment.

Current consumed by the Base Units, Memory Modules, Real Time Clock Modules, and the End Cap Terminators (for systems utilizing Compact I/O expansion) has already been factored into the calculations. A system is valid if the current and power requirements are satisfied.

**TIP**

An End Cap Terminator (catalog number 1769-ECR or -ECL) is needed for any system using Compact expansion I/O.

---

**IMPORTANT**

In a MicroLogix 1500 system, a maximum of one 1769 expansion cable can be used, allowing for two banks of I/O modules. One bank is connected directly to the controller and the other is connected via the expansion cable. The bank connected to the controller uses the controller's embedded power supply. The bank connected via the cable requires its own power supply.

---

### System Expansion Calculations

A download is also available for system validation. On the Internet, go to <http://www.ab.com/micrologix> and navigate to MicroLogix 1500.

The procedure in this publication consists of:

- Selecting System Devices
- Verifying the System Loading

## Selecting System Devices

1. Use Table F.1 to select the processor and optional communications or display devices. Enter a 1 in the “Select Devices” column.
2. Enter the current draw values in the “Calculated Current for System” columns. If an external power supply will be used to power communication devices, do not include their current draw values in this calculation. Add up the current draw values to determine the “SUBTOTAL1” values.

**Table F.1 Selecting Hardware: Base Unit and Communications/Display Devices**

Catalog Number	Select Device(s)	Bus Current Draw Specification		Calculated Current for System	
		at 5V dc (mA)	at 24V dc (mA)	at 5V dc (mA)	at 24V dc (mA)
<i>Choose a Processor, LSP or LRP:</i>					
1764-LSP		300	0		
1764-LRP		380	0		
1764-DAT <sup>(1)</sup> optional		350	0		
<i>Communications/Display Devices, optional, one only maximum:</i>					
1761-NET-AIC <sup>(1)</sup>		0	120 <sup>(2)</sup>		
1761-NET-ENI <sup>(1)</sup>		0	100 <sup>(2)</sup>		
2707-MVH232 or 2707-MVP232 <sup>(1)</sup>		0	80 <sup>(2)</sup>		
<b>SUBTOTAL1</b>				<b>(A1)</b>	<b>(B1)</b>

(1) These are optional accessories. Current is consumed only if the accessory is installed.

(2) Current for the AIC+ and ENI may be supplied by controller communications port or from an external 24V dc source. No current is consumed from the controller when a user-supplied, external source is used. If an external source is to be used, do not select the device here. The current for a 2707-MVH232 or 2707-MVP232 MicroView Operator Interface is supplied from the controller communication port, when directly connected.

3. Use Table F.2 to select the I/O modules. Enter the number of modules in either the “Base Unit Expansion” or the “Bank 1” column.

### IMPORTANT

When planning the system layout, keep in mind that each module has a “Power Supply Distance Rating”. This is the maximum distance an I/O module may be located from the power supply. For most modules, the rating is 8. For the 1769-HSC and 1769-SDN, the rating is 4.

Depending on its configuration, the 1769-SDN may transfer large amounts of data into and out of the controller I/O image tables. Care should be taken when using more than three of these modules to verify that they are optimally configured. This will

ensure that the maximum available 4K data table size will not be exceeded. Refer to the 1769-SDN User Manual for more details.

4. Enter the current draw values in the “Calculated Current” columns. Add up the current draw values to determine the “SUBTOTAL2” values.

5. Verify that the total number of modules does not exceed the system limits using the maximum values for the base unit and Table F.5 for the expansion power supply, if used.

**Table F.2 Selecting Hardware: Expansion I/O**

<i>Select I/O Modules for Each Bank:</i>			<b>Bus Current Draw Specification (mA)</b>		<i>Calculate Current Draw:</i>			
<b>Expansion I/O Modules</b>	<b>Base Unit Expansion (1)</b>	<b>Bank 1<sup>(2)</sup></b>			<b>Calculated Current for Base Unit Expansion (mA)</b>		<b>Calculated Current for Bank 1 Power Supply (mA)<sup>(3)</sup></b>	
	<b>n1</b>	<b>n2</b>	<b>X</b>	<b>Y</b>	<b>n1 x X</b>	<b>n1 x Y</b>	<b>n2 x X</b>	<b>n2 x Y</b>
	<b>Number of Modules<sup>(4)</sup></b>		<b>at 5V dc</b>	<b>at 24V dc</b>	<b>at 5V dc</b>	<b>at 24V dc</b>	<b>at 5V dc</b>	<b>at 24V dc</b>
1769-HSC <sup>(5)</sup>			425	0				
1769-IA16			115	0				
1769-IA8I			90	0				
1769-IF4 (Series A)			120	150				
1769-IF4 (Series B)			120	60				
1769-IF4XOF2			120	160				
1769-IM12			100	0				
1769-IQ16			115	0				
1769-IQ6XOW4			105	50				
1769-IR6			100	45				
1769-IT6			100	40				
1769-OA8			145	0				
1769-OA16			225	0				
1769-OB16			200	0				
1769-OB16P			160	0				
1769-OF2 (Series A)			120	200				
1769-OF2 (Series B)			120	120				
1769-OV16			200	0				
1769-OW8			125	100				
1769-OW8I			125	100				
1769-OW16			205	180				
1769-SDN			440	0				
<b>TOTAL MODULES:</b>			<b>SUBTOTAL2:</b>		<b>(A2)</b>	<b>(B2)</b>	<b>(C)</b>	<b>(D)</b>

(1) May not exceed 8 I/O modules.

(2) No more than 8 I/O modules on either side of the power supply.

(3) Maximum value depends on the power supply chosen.

(4) Up to 16 modules may be used in a MicroLogix 1500 system when using a Series B Base Unit and Series C processor (up to 8 for Series A Base Units).

A maximum of 8 modules can be connected directly to the Base Unit.

A maximum of 8 modules can be connected to each side of the Expansion Power Supply.

(5) No more than 4 I/O modules may be connected to the base unit or to either side of the expansion power supply when the 1769-HSC or 1769-SDN are used in the system.

## Verifying the System Loading

To have a valid system, both current and power requirements must be satisfied.

### Verifying the Base Unit Loading

1. Enter the SUBTOTAL values from Tables F.1 and F.2. Add the total current draw for the Base Unit. Verify the values are within the maximum limits.

**Table F.3 Base Unit Power Supply Loading - Verify the Current Limits**

Current from:	Calculated Current for System	
	at 5V dc (mA)	at 24V dc (mA)
For 1764-24BWA only, enter sum of any User 24V dc Sensor Current		(E)
<b>MAXIMUM LIMIT</b>	n/a	<b>400 mA User 24V dc</b>
Values from SUBTOTAL1 (Table F.1)	(A1)	(B1)
Values from SUBTOTAL2 (Table F.2)	(A2)	(B2)
<b>TOTAL BASE UNIT CURRENT LOADING</b>	<b>(F)</b>	<b>(G)</b>
<b>MAXIMUM LIMIT</b>	<b>2250 mA at 5V dc</b>	<b>400 mA at 24V dc</b>

2. Using the table below, verify that the MAXIMUM POWER LIMIT is not exceeded.

**Table F.4 Base Unit Power Supply Loading - Verify the Required Power**

Catalog Number:	1764-24AWA, 1764-28BXB Base Units			1764-24BWA Base Unit		
5V Power Calculation	(F)	x 5V	= W	(F)	x 5V	= W
24V Power Calculation	(G)	x 24V	= W	(G)	x 24V	= W
				(E)	x 24V	= W
<b>Add up Total Watts</b>			<b>W</b>			<b>W</b>
<b>MAXIMUM POWER LIMIT</b>			<b>16W</b>			<b>22W</b>

### Verifying the Expansion Power Supply Loading

Using the values from SUBTOTAL2, verify that the system loading and I/O distribution are within the limits shown in Table F.5. Consider future expansion when selecting a power supply.

**Table F.5 Bank 1 Power Supply Loading - Verify the Current Limits**

Specification	Catalog Number	Calculated Current for System		24V dc User Output Capacity
		at 5V dc (mA)	at 24V dc (mA)	
Values from SUBTOTAL2 (Table F.2):		(C)	(D)	
<b>MAXIMUM CURRENT LIMIT</b>	<b>1769-PA2</b>	<b>2000</b>	<b>800</b>	<b>250 mA</b>
	<b>1769-PA4</b>	<b>4000</b>	<b>2000</b>	n/a
	<b>1769-PB2</b>	<b>2000</b>	<b>800</b>	
	<b>1769-PB4</b>	<b>4000</b>	<b>2000</b>	
I/O Distribution - Distribute I/O modules such that the current consumed from either the left side or the right side of the power supply never exceeds the following values:	1769-PA2	2000	800	<b>250 mA</b>
	1769-PA4	2000	1000	n/a
	1769-PB2	2000	800	
	1769-PB4	2000	1000	

*System Using a 1769-PA2*

To validate your system, the total 5V dc current and 24V dc current consumed must be considered. The I/O modules must be distributed, such that the current consumed from the left *or* right side of the power supply never exceeds 2A at 5V dc and 1.0A at 24V dc. Use the current graphs below to determine if the power supply loading in your system is within the allowable range.

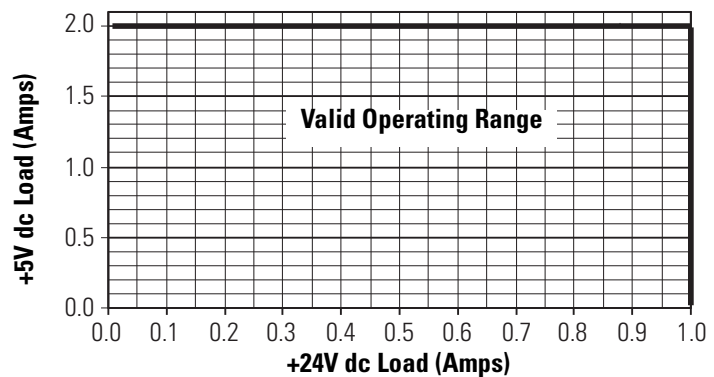
**Figure F.1 1769-PA2 Current with +24V dc User Load = 0A**

**Figure F.2 1769-PA2 Current with +24V dc User Load = 0.2A**

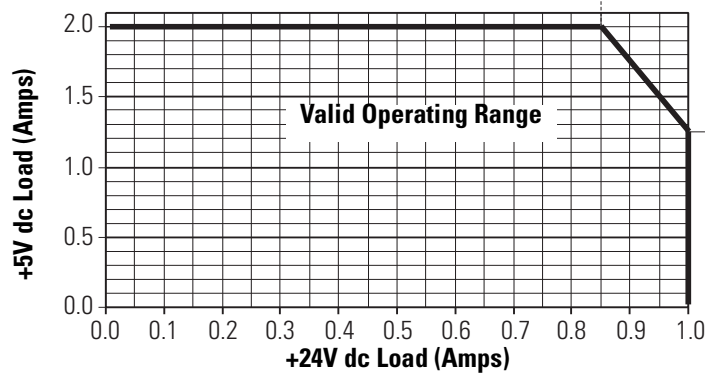

**Figure F.3 1769-PA2 Current with +24V dc User Load = 0.25A**

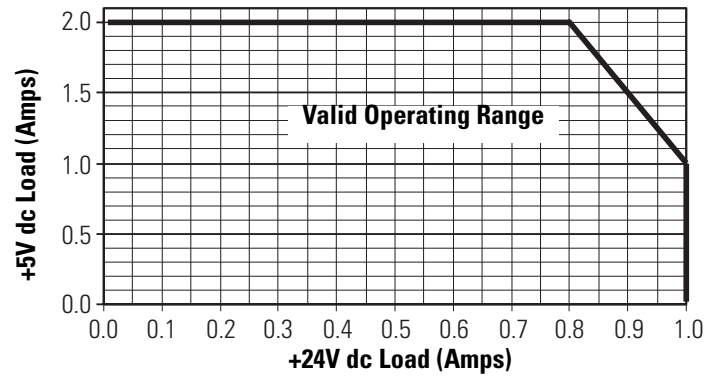

*System Using a 1769-PB2*

To validate your system, the total 5V dc current and 24V dc current consumed must be considered. The I/O modules must be distributed, such that the current consumed from the left *or* right side of the power supply never exceeds 2A at 5V dc and 1.0A at 24V dc. Use the current graph below to determine if the power supply loading in your system is within the allowable range.

**Figure F.4 1769-PB2 Current**

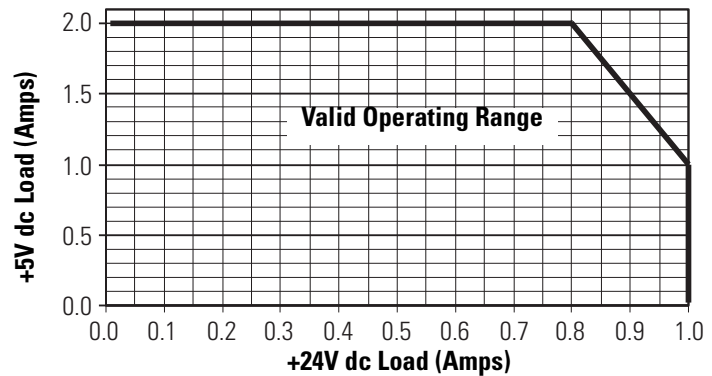



### System Using a 1769-PA4

To validate your system, the total 5V dc current and 24V dc current consumed must be considered. The I/O modules connected to the PB2 should be distributed, such that the current consumed from the left and right side of the power supply never exceeds 2A at 5V and 0.8A at 24V dc with an ambient temperature of 0 to 55°C. Use the current graph below to determine if the power supply loading in your system is:

- within the allowable range for special load conditions
- above 55° to 60°C.

**Figure 7 1769-PA4 5V and 24V dc Current**

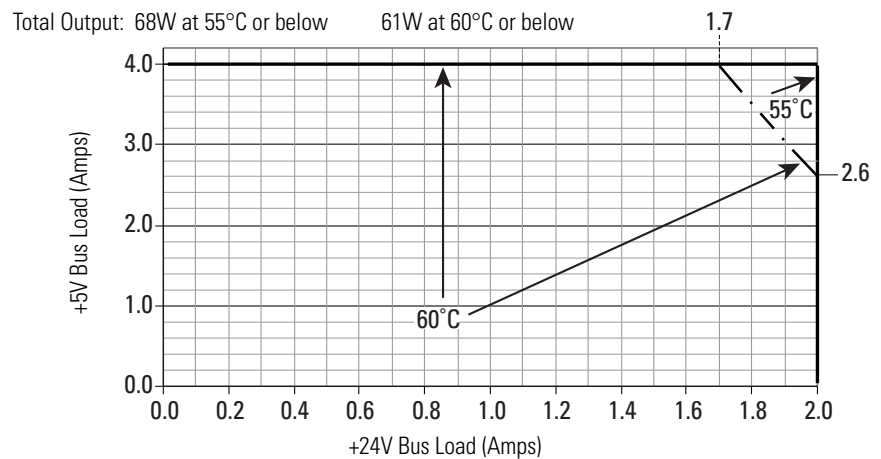

### System Using a 1769-PB4

To validate your system, the total 5V dc current and 24V dc current consumed must be considered. The I/O modules connected to the PB2 should be distributed, such that the current consumed from the left and right side of the power supply never exceeds 2A at 5V and 0.8A at 24V dc with an ambient temperature of 0 to 55°C. Use the current graph below to determine if the power supply loading in your system is:

- within the allowable range for special load conditions
- above 55° to 60°C.

Figure 8 1769-PB4 5V and 24V dc Current

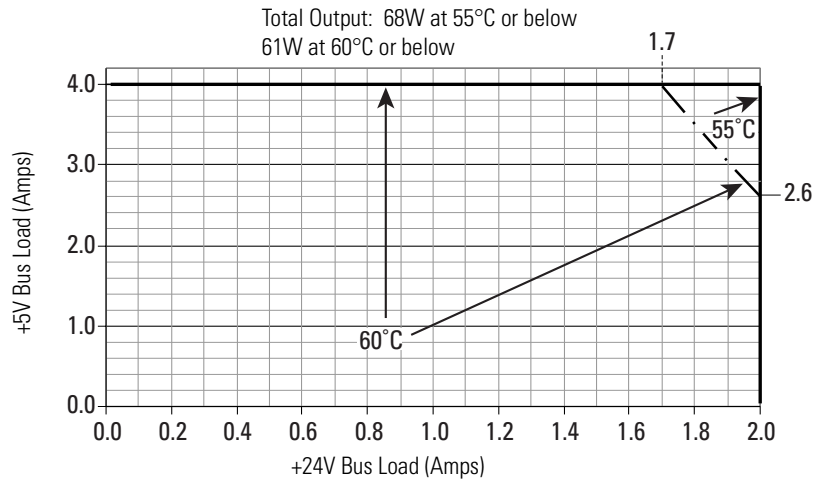

## Calculating Heat Dissipation

Use this procedure when you need to determine the heat dissipation for installation in an enclosure. Use the following table.

Catalog Number	Heat Dissipation		
	Equation or Constant	Calculation	Subtotal
1764-24AWA	$18W + (0.3 \times \text{System Loading})$	$18W + (0.3 \times \text{_____ } W)$	
1764-24BWA	$20W + (0.3 \times \text{System Loading})$	$20W + (0.3 \times \text{_____ } W)$	
1764-28BXB	$20W + (0.3 \times \text{System Loading})$	$20W + (0.3 \times \text{_____ } W)$	
1764-DAT	1.75W		
1769-HSC	$6.21W \times \text{number of modules}$	$6.21W \times \text{_____}$	
1769-IA16	$3.30W \times \text{number of modules}$	$3.30W \times \text{_____}$	
1769-IA8I	$1.81W \times \text{number of modules}$	$1.81W \times \text{_____}$	
1769-IF4 (Series A)	$3.99W \times \text{number of modules}$	$3.99W \times \text{_____}$	
1769-IF4 (Series B)	$2.63W \times \text{number of modules}$	$2.63W \times \text{_____}$	
1769-IF4XOF2	$3.03W \times \text{number of modules}$	$3.03W \times \text{_____}$	
1769-IM12	$3.65W \times \text{number of modules}$	$3.65W \times \text{_____}$	
1769-IQ16	$3.55W \times \text{number of modules}$	$3.55W \times \text{_____}$	
1769-IQ6XOW4	$2.75W \times \text{number of modules}$	$2.75W \times \text{_____}$	
1769-IR6	$1.50W \times \text{number of modules}$	$1.50W \times \text{_____}$	
1769-IT6	$1.50W \times \text{number of modules}$	$1.50W \times \text{_____}$	
1764-LSP	1.5W		
1764-LRP	1.9W		
1764-MM1, -RTC, -MM1/RTC	0		
1769-OA8	$2.12W \times \text{number of modules}$	$2.12W \times \text{_____}$	
1769-OA16	$4.9W \times \text{number of modules}$	$4.9W \times \text{_____}$	
1769-OB16	$2.11W \times \text{number of modules}$	$2.11W \times \text{_____}$	
1769-OB16P	$2.69W \times \text{number of modules}$	$2.69W \times \text{_____}$	
1769-OF2 (Series A)	$4.77W \times \text{number of modules}$	$4.77W \times \text{_____}$	
1769-OF2 (Series B)	$2.52W \times \text{number of modules}$	$2.52W \times \text{_____}$	
1769-OV16	$2.06W \times \text{number of modules}$	$2.06W \times \text{_____}$	
1769-OW8	$2.83W \times \text{number of modules}$	$2.83W \times \text{_____}$	
1769-OW8I	$2.83W \times \text{number of modules}$	$2.83W \times \text{_____}$	
1769-OW16	$4.75W \times \text{number of modules}$	$4.75W \times \text{_____}$	
1769-SDN	$3.8W \times \text{number of modules}$	$3.8W \times \text{_____}$	
<b>Add Subtotals to determine Heat Dissipation</b>			



The following terms are used throughout this manual. Refer to the *Allen-Bradley Industrial Automation Glossary*, Publication Number AG-7.1, for a complete guide to Allen-Bradley technical terms.

### **address**

A character string that uniquely identifies a memory location. For example, I:1/0 is the memory address for data located in Input file word 1, bit 0.

### **AIC+ Advanced Interface Converter**

A device that provides RS-232 isolation to an RS-485 Half-Duplex communication link. (Catalog Number 1761-NET-AIC.)

### **application**

- 1) A machine or process monitored and controlled by a controller.
- 2) The use of computer- or processor-based routines for specific purposes.

### **baud rate**

The speed of communication between devices. Baud rate is typically displayed in *K baud*. For example, 19.2K baud = 19,200 bits per second.

### **bit**

The smallest unit of memory used in discrete or binary logic, where the value 1 represents ON and 0 represents OFF.

### **block diagrams**

A method used to illustrate logic components or a sequence of events.

### **Boolean operators**

Logical operators such as AND, OR, NAND, NOR, NOT, and Exclusive-OR that can be used singularly or in combination to form logic statements or circuits. Can have an output response of T or F.

### **branch**

A parallel logic path within a rung of a ladder program. Its primary use is to build OR logic.

**communication scan**

A part of the controller's operating cycle. Communication with devices (such as other controllers and operator interface devices) takes place during this period.

**control program**

User logic (the application) that defines the controller's operation.

**controller**

A device, such as a programmable controller, used to control output devices.

**controller overhead**

A portion of the operating cycle used for housekeeping purposes (memory checks, tests, communications, etc.).

**counter**

A device that counts the occurrence of an event.

**CPU (Central Processing Unit)**

The decision-making and data storage section of a programmable controller.

**data table**

The part of processor memory that contains I/O status and files where user data (such as bit, integer, timers, and counters) is monitored, manipulated, and changed for control purposes.

**DIN rail**

Manufactured according to Deutsche Industrie Normenausshus (DIN) standards, a metal railing designed to ease installation and mounting of your devices.

**download**

The transfer of program or data files to a device.

**DCD**

Data Carrier Detect. A signal generated by a modem that represents traffic (activity) on a communications network.

**DTE**

Data Terminal Equipment

**EMI**

Electromagnetic interference.

**embedded I/O**

Embedded I/O is the controller's on-board I/O. For MicroLogix controllers, embedded I/O is all I/O residing at slot 0.

**expansion I/O**

Expansion I/O is I/O that is connected to the controller via a bus or cable. MicroLogix 1200 controllers use Bulletin 1762 expansion I/O. MicroLogix 1500 controllers use Bulletin 1769 expansion I/O. For MicroLogix controllers, expansion I/O is all I/O residing at slot 1 and higher.

**encoder**

A device that detects position, and transmits a signal representing that position.

**executing mode**

Any run, remote run, or test mode.

**false**

The status of an instruction that does not provide a continuous logical path on a ladder rung.

**FIFO (First-In-First-Out)**

The order that data is stored and retrieved from a file.

**file**

A collection of data or logic organized into groups.

**full-duplex**

A mode of communication where data may be transmitted and received simultaneously (contrast with half-duplex).

**half-duplex**

A mode of communication where data transmission is limited to one direction at a time.

**hard disk**

A storage device in a personal computer.

**high byte**

Bits 8 to 15 of a word.

**housekeeping**

The portion of the scan when the controller performs internal checks and services communications.

**input device**

A device, such as a push button or a switch, that supplies an electrical signal to the controller.

**input scan**

The controller reads all input devices connected to the input terminals.

**inrush current**

The temporary surge of current produced when a device or circuit is initially energized.

**instruction**

A mnemonic defining an operation to be performed by the processor. A rung in a program consists of a set of input and output instructions. The input instructions are evaluated by the controller as being true or false. In turn, the controller sets the output instructions to true or false.

**instruction set**

The set of instructions available within a controller.

**I/O**

Input and Output



**jump**

Changes the normal sequence of program execution. In ladder programs a JUMP (JMP) instruction causes execution to jump to a specific rung in the user program.

**ladder logic**

A graphical programming format resembling a ladder-like diagram. The ladder logic programming language is the most common programmable controller language.

**least significant bit (LSB)**

The element (or bit) in a binary word that carries the smallest value of weight.

**LED (Light Emitting Diode)**

Used as status indicator for processor functions and inputs and outputs.

**LIFO (Last-In-First-Out)**

The order that data is stored and retrieved from a file.

**low byte**

Bits 0 to 7 of a word.

**logic**

A general term for digital circuits or programmed instructions to perform required decision making and computational functions.

**Master Control Relay (MCR)**

A hard-wired relay that can be de-energized by any series-connected emergency stop switch.

**mnemonic**

A simple and easy to remember term that is used to represent a complex or lengthy set of information.

**Modbus™ RTU Slave**

A serial communication protocol.

**modem**

Modulator/demodulator. Equipment that connects data terminal equipment to a communication line.

**modes**

Selected methods of operation. Example: run, test, or program.

**negative logic**

The use of binary logic in such a way that “0” represents the desired voltage level.

**network**

A series of stations (nodes) connected by some type of communication medium. A network may be made up of a single link or multiple links.

**nominal input current**

The typical amount of current seen at nominal input voltage.

**normally closed**

Contacts on a relay or switch that are closed when the relay is de-energized or deactivated. They are open when the relay is energized or the switch is activated.

**normally open**

Contacts on a relay or switch that are open when the relay is de-energized or the switch is deactivated. They are closed when the relay is energized or the switch is activated.

**off-delay time**

The OFF delay time is a measure of the time required for the controller logic to recognize that a signal has been removed from the input terminal of the controller. The time is determined by circuit component delays and by any applied filter.

**offline**

When a device is not scanning/controlling or when a programming device is not communicating with the controller.

**offset**

A continuous deviation of a controlled variable from a fixed point.

**off-state leakage current**

When a mechanical switch is opened (off-state), no current flows through the switch. Semiconductor switches and transient suppression components which are sometimes used to protect switches, have a small current flow when they are in the off state. This current is referred to as the off-state leakage current. To ensure reliable operation, the off-state leakage current rating must be less than the minimum operating current rating of the device that is connected.

**on-delay time**

The ON delay time is a measure of the time required for the controller logic to recognize that a signal has been presented at the input terminal of the controller.

**one shot**

A programming technique that sets a bit ON or OFF for one program scan.

**online**

When a device is scanning/controlling or when a programming device is communicating with the controller.

**operating voltage**

For inputs, the voltage range needed for the input to be in the On state. For outputs, the allowable range of user-supplied voltage.

**output device**

A device, such as a pilot light or a motor starter coil, that receives a signal or command from the controller.

**output scan**

The controller turns on, off, or modifies the devices connected to the output terminals.

**PCCC**

Programmable Controller Communications Commands

**processor**

A Central Processing Unit. (See CPU.)

**processor files**

The set of program and data files resident in the controller.

**program file**

Areas within a processor that contain the logic programs. MicroLogix controllers support multiple program files.

**program mode**

When the controller is not scanning the control program.

**program scan**

A part of the controller's operating cycle. During the program scan, the logic program is processed and the Output Image is updated.

**programming device**

Programming package used to develop ladder logic diagrams.

**protocol**

The rules of data exchange via communications.

**read**

To acquire data. For example, the processor reads information from other devices via a read message.

**relay**

An electrically operated device that mechanically switches electrical circuits.

**relay logic**

A representation of binary or discrete logic.

**restore**

To transfer a program from a device to a controller.

**reserved bit**

A location reserved for internal use.

**retentive data**

Information (data) that is preserved through power cycles.

**RS-232**

An EIA standard that specifies electrical, mechanical, and functional characteristics for serial binary communication circuits.

**run mode**

An executing mode during which the controller scans or executes the logic program.

**rung**

A rung contains input and output instructions. During Run mode, the inputs on a rung are evaluated to be true or false. If a path of true logic exists, the outputs are made true (energized). If all paths are false, the outputs are made false (de-energized).

**RTU**

Remote Terminal Unit

**save**

To save a program to a computer hard disk.

**scan**

The scan is made up of four elements: input scan, program scan, output scan, and housekeeping.

**scan time**

The time required for the controller to complete one scan.

**sinking**

A term used to describe current flow between two devices. A sinking device provides a direct path to ground.

**sourcing**

A term used to describe current flow between two devices. A sourcing device or circuit provides a power.

**status**

The condition of a circuit or system.

**terminal**

A point on an I/O module that external devices, such as a push button or pilot light, are wired to.

**throughput**

The time between when an input turns on and a corresponding output turns on or off. Throughput consists of input delays, program scan, output delays, and overhead.

**true**

The status of an instruction that provides a continuous logical path on a ladder rung.

**upload**

Data is transferred from the controller to a programming or storage device.

**watchdog timer**

A timer that monitors a cyclical process and is cleared at the conclusion of each cycle. If the watchdog runs past its programmed time period, it causes a fault.

**write**

To send data to another device. For example, the processor writes data to another device with a message write instruction.

## Numerics

- 1764-24AWA**
  - features 1-1
- 1764-24AWA wiring diagram** 3-11
- 1764-24BWA**
  - features 1-1
- 1764-24BWA sinking wiring diagram**
  - 3-12
- 1764-24BWA sourcing wiring diagram**
  - 3-13
- 1764-28BXB**
  - features 1-1
- 1764-28BXB sinking wiring diagram** 3-14
- 1764-28BXB sourcing wiring diagram**
  - 3-15
- 1764-LRP processor** 1-3
- 1764-LSP processor** 1-3

## A

- address** G-1
- AIC+**
  - applying power to 4-20
  - attaching to the network 4-20
  - connecting 4-15
    - isolated modem 4-5
  - installing 4-20
  - recommended user supplied components 4-19
  - selecting cable 4-17
- AIC+ Advanced Interface Converter** G-1
- Allen-Bradley**
  - contacting for assistance C-5
  - support P-3
- application** G-1
- ASCII protocol** E-13
- attach and lock module** 2-22

## B

- base comms door** B-6
- base terminal door** B-6
- base unit panel mounting** 2-16
- base units**
  - hardware overview 1-2
- battery**
  - processor battery life expectancy B-2
  - processor replacement battery B-2
  - RTC battery life expectancy 6-3

- baud rate** G-1
- bit** G-1
- bit key** 5-3
- Bit Mode** 5-6
- block diagrams** G-1
- Boolean operators** G-1
- branch** G-1

## C

- Cables** 4-23
- cables**
  - hardware overview 1-4
  - planning routes for DH485 connections E-9
  - selection guide for the AIC+ 4-17
  - selection guide for the DeviceNet network 4-22
- calling Allen-Bradley for assistance** C-5
- CE mark** 2-1
- certification** 2-1
- channel configuration**
  - DF1 full-duplex E-1
- clearing faults** C-4
- common techniques used in this manual**
  - P-3
- communication**
  - DeviceNet 4-22, 4-23
- communication protocols**
  - DF1 fullduplex E-1
  - DF1 halfduplex E-2
  - DH485 E-5
  - Modbus E-13
- communication scan** G-2
- compact I/O**
  - attach and lock module 2-22
  - installing 2-22
- component descriptions** 1-2
  - accessories
    - cables 1-4
      - programming 1-5
  - base units 1-2
  - data access tool 1-3
  - end cap 1-6
  - expansion I/O 1-6
  - memory modules/real-time clock 1-3
  - processor 1-3
- components**
  - installing 2-17

**connecting the system**

- AIC+ 4-15
- DeviceNet network 4-22, 4-23
- DF1 fullduplex protocol 4-3
- DH485 network 4-10

**contactors (bulletin 100), surge suppressors for 3-6****control program G-2****ControlFlash**

- missing/corrupt OS LED pattern D-2
- sequence of operation D-2
- using D-1

**controller**

- definition G-2
- determining faults C-1
- fault messages C-5
- features 1-1
- grounding 3-6
- installation 2-1
- mounting 2-13
- overhead G-2
- preventing excessive heat 2-7
- troubleshooting C-1

**controller error recovery model C-3****controller faults C-1****controller LED status C-1****controller operation**

- normal C-2

**counters**

- definition G-2

**CPU (central processing unit), definition G-2****CSA certification**

- see C-UL 2-1

**C-UL certification 2-1****D****DAT**

- Communication Errors 5-9
- configuration 5-4
- Controller Faults Displayed 5-8
- display 5-5
- Error Conditions 5-9
- Internal Errors 5-9
- keypad 5-3
- power-up operation 5-3

**DAT Function File 5-4****data access tool**

- hardware overview 1-3
- installing 2-19

**data table G-2****DCD, definition G-2****DeviceNet Communications 4-22, 4-23****DeviceNet network**

- connecting 4-22, 4-23
- selecting cable 4-22

**DF1 fullduplex protocol**

- configuration parameters E-1
- connecting 4-3
- description E-1
- using a modem 4-5, E-3

**DF1 halfduplex protocol**

- description E-2

**DH485 communication protocol**

- configuration parameters 4-12, E-6

**DH485 network**

- configuration parameters E-10
- connecting 4-10
- description E-5
- devices that use the network E-7
- installation 4-12
- planning considerations E-8
- protocol E-6
- token rotation E-6

**DIN rail G-2**

- mounting 2-14
- removing your base unit 2-15

**disconnecting main power 2-4****download G-2****DTE, definition G-3****E****Electronics Industries Association (EIA)**

- E-1

**electrostatic discharge**

- preventing 2-17

**EMC 2-1****EMC Directive 2-1****emergency-stop switches 2-9****EMI G-3****encoder**

- definition G-3

**end cap**

- hardware overview 1-6

**ENTER key 5-3****error recovery model C-3**



**errors**

- controller C-2
- hardware C-2
- identifying C-4

**ESC key** 5-3**European Union Directive compliance**

2-1

**executing mode** G-3**expansion I/O**

hardware overview 1-6

**F****F1 Functions** 5-7**F1 key** 5-3**F2 Functions** 5-7**F2 key** 5-3**false** G-3**fault recovery procedure** C-4**fault routine** C-4**faults**

- automatically clearing C-4
- identifying C-4
- manually clearing using the fault routine C-4

**FET output specifications**

1764-28BxB A-5

**FIFO (First-In-First-Out)** G-3**file** G-3**full-duplex** G-3**G****grounding the controller** 3-6**H****half-duplex** G-4**hard disk** G-4**hardware**

features 1-1

**hardware overview** 1-1**hazardous location** 2-3**heat protection** 2-7**high byte** G-4**housekeeping** G-4**I****I/O** G-4**identifying controller faults** C-4**input device** G-4**input scan** G-4**input specifications** A-3**input states on power down** 2-6**inrush current** G-4**installing**

- ControlFlash software D-1
- your controller 2-1

**installing controller components**

- compact I/O 2-22
- data access tool 2-19
- memory module/real-time clock 2-20
- processor 2-17

**installing your base unit**

- on DIN rail 2-15
- using mounting screws 2-16

**instillation** 2-17**instruction** G-4**instruction set**

definition G-4

**integer key** 5-3**Integer Mode** 5-6**isolated link coupler**

installing 4-12

**isolation transformers**

power considerations 2-5

**J****jump** G-5**K****keypad** 5-3**L****ladder logic** G-5**least significant bit (LSB)** G-5**LED (light emitting diode)** G-5**LEDs**

- error with controller C-2
- normal controller operation C-1
- status C-1

**LIFO (Last-In-First-Out)** G-5

**lithium battery (1747-BA)**

- disposing B-4
- handling B-3
- installing B-2
- manufacturer B-4
- storing B-3
- transporting B-3

**logic** G-5**low byte** G-5**M****manuals, related** P-2**master control relay** 2-8**master control relay (MCR)** G-5**master control relay circuit**

- periodic tests 2-5

**memory module**

- data file protection 6-4
- program compare 6-4
- program/data backup 6-3
- removal/installation under power 6-1,  
6-5

**Memory Module Information File** 6-5**memory module/real-time clock**

- installing 2-20

**mnemonic** G-5**Modbus communication protocol** E-13**Modbus definition** G-5**modem** G-6**modem cable**

- constructing your own 4-6

**modems**

- dialup phone E-4
- leasedline E-4
- line drivers E-5
- radio E-5
- using with MicroLogix controllers E-3

**modes** G-6**monitoring**

- controller operation
- fault recovery procedure C-4

**motor starters (bulletin 509)**

- surge suppressors 3-6

**motor starters (bulletin 709)**

- surge suppressors 3-6

**mounting**

- dimensions 2-12
- the controller 2-13
- using DIN rail 2-14

**N****negative logic** G-6**network** G-6**nominal input current** G-6**normally closed** G-6**normally open** G-6**null modem cable** 4-6**O****offline** G-6**offset** G-7**off-state leakage current** G-7**one shot** G-7**online** G-7**operating voltage** G-7**output device** G-7**output scan** G-7**output specifications** A-5

- 1764-28BxB FET A-5

**P****panel mounting**

- base unit 2-16

**PCCC** G-7**planning considerations for a network**

- E-8

**power considerations**

- input states on power down 2-6
- isolation transformers 2-5
- loss of power source 2-6
- other line conditions 2-7
- overview 2-5
- power supply inrush 2-6

**power distribution** 2-5**Power Save Timeout** 5-4**power source**

- loss of 2-6

**power supply inrush**

- power considerations 2-6

**preparing for upgrade** D-1**preventing excessive heat** 2-7**processor**

- hardware overview 1-3

**processor** G-8

- installing 2-17

**processor access door** B-6**processor files** G-8

**program faults**  
     determining C-1  
**program file**  
     definition G-8  
**program mode** G-8  
**program scan**  
     definition G-8  
**programming device** G-8  
**programming the controller**  
     required software 1-5  
**PROTECTED indicator light** 5-3, 5-5  
**protocol** G-8  
**publications, related** P-2  
**Purpose of this Manual** P-1

**R**

**read** G-8  
**real time clock**  
     battery low indicator bit 6-2  
     disabling 6-3  
**Real Time Clock Function File** 6-1  
**related publications** P-2  
**relay** G-8  
**relay contact rating table** A-5  
**relay logic** G-8  
**relays**  
     surge suppressors for 3-6  
**remote packet support** E-11  
**replacement battery** B-2  
     disposing B-4  
     handling B-3  
     installing B-2  
     storing B-3  
     transporting B-3  
**replacement doors** B-6  
     base comms door B-6  
     base terminal door B-6  
     processor access door B-6  
     trim pots/mode switch cover door B-6  
**replacement kits** B-1  
**replacement parts** B-1  
     base comms door B-6  
     base terminal door B-6  
     processor access door B-6  
     terminal blocks B-5  
     trim pots/mode switch cover door B-6  
**replacement terminal blocks** B-5  
**reserved bit** G-9

**response times for high-speed dc inputs**  
     A-4  
**response times for normal dc inputs** A-4  
**restore** G-8  
**retentive data** G-9  
**RS-232 communication interface** E-1  
**RS-232, definition** G-9  
**RTU, definition** G-9  
**run mode** G-9  
**rung** G-9

## S

**safety circuits** 2-4  
**safety considerations**  
     disconnecting main power 2-4  
     periodic tests of master control relay  
         circuit 2-5  
     power distribution 2-5  
     safety circuits 2-4  
**save** G-9  
**scan** G-9  
**scan time** G-9  
**sinking** G-9  
**sinking and sourcing circuits** 3-10  
**sinking wiring diagram**  
     1764-28BXB 3-14  
**sourcing** G-10  
**sourcing wiring diagram**  
     1764-28BXB 3-15  
**spade lug wiring** 3-3  
**specifications**  
     input A-3  
     output A-5  
     relay contact rating table A-5  
     response times for high-speed dc inputs  
         A-4  
     response times for normal dc inputs A-4  
     working voltage (1764-24AWA) A-7  
     working voltage (1764-24BWA) A-7  
     working voltage (1764-28BXB) A-8  
**status** G-10  
**surge suppressors**  
     for contactor 3-6  
     for motor starters 3-6  
     for relays 3-6  
     recommended 3-6  
     using 3-4

## T

- terminal** G-10
- throughput** G-10
- Trim Pot Information Function File** 5-2
- trim pots**
  - adjustment 5-1
  - error conditions 5-2
  - location 5-1
- trim pots/mode switch cover door** B-6
- troubleshooting**
  - automatically clearing faults C-4
  - contacting Allen-Bradley for assistance C-5
  - controller error recovery model C-3
  - determining controller faults C-1
  - identifying controller faults C-4
  - manually clearing faults C-4
  - understanding the controller LED status C-1
  - using the fault routine C-4
- true** G-10

## U

- UL certification** 2-1
- upload** G-10

## W

- wire requirements** 3-1
- wiring**
  - spade lug 3-3
- wiring diagrams** 3-8
- wiring recommendation** 3-2
- wiring your controller** 3-1
- Working Screen Operation** 5-7
- working voltage (1764-24AWA)**
  - specifications A-7
- working voltage (1764-24BWA)**
  - specifications A-7
- working voltage (1764-28BXB)**
  - specifications A-8
- write** G-10



**[www.rockwellautomation.com](http://www.rockwellautomation.com)**

**Corporate Headquarters**

Rockwell Automation, 777 East Wisconsin Avenue, Suite 1400, Milwaukee, WI, 53202-5302 USA, Tel: (1) 414.212.5200, Fax: (1) 414.212.5201

**Headquarters for Allen-Bradley Products, Rockwell Software Products and Global Manufacturing Solutions**

Americas: Rockwell Automation, 1201 South Second Street, Milwaukee, WI 53204-2496 USA, Tel: (1) 414.382.2000, Fax: (1) 414.382.4444

Europe: Rockwell Automation SA/NV, Vorstlaan/Boulevard du Souverain 36-BP 3A/B, 1170 Brussels, Belgium, Tel: (32) 2 663 0600, Fax: (32) 2 663 0640

Asia Pacific: Rockwell Automation, 27/F Citicorp Centre, 18 Whitfield Road, Causeway Bay, Hong Kong, Tel: (852) 2887 4788, Fax: (852) 2508 1846

**Headquarters for Dodge and Reliance Electric Products**

Americas: Rockwell Automation, 6040 Ponders Court, Greenville, SC 29615-4617 USA, Tel: (1) 864.297.4800, Fax: (1) 864.281.2433

Europe: Rockwell Automation, Brühlstraße 22, D-74834 Elztal-Dallau, Germany, Tel: (49) 6261 9410, Fax: (49) 6261 17741

Asia Pacific: Rockwell Automation, 55 Newton Road, #11-01/02 Revenue House, Singapore 307987, Tel: (65) 351 6723, Fax: (65) 355 1733

Publication 1764-UM001B-EN-P - April 2002

PN 40072-091-01(2)

Supersedes Publication 1764-UM001A-US-P - April 2000

Copyright © 2002 Rockwell Automation. All rights reserved. Printed in the U.S.A.